



EXPAIR

Precision air handling cabinets

Compact footprint

Dual-wall construction

Fan motor assembly with

EC motor (electronically commutated)

PLC control

Condenser fan variable speed control



Chilled water :

Cooling capacity : 5 to 27 kW

Air flow rate : 800 to 6 000 m³/h

Direct expansion :

Cooling capacity : 5 to 47 kW

Air flow rate : 800 to 12 000 m³/h

USE

Precision air conditioning cabinet specially designed for the air handling requirements (filtration, temperature and humidity control) of computer rooms, telecommunications rooms and specific purpose rooms (electronics, sensitive storage, medical, controlled atmosphere rooms, etc.).

Dual-wall construction. The choice of technology used (self regulation depending on the room loads, EC motor: electronically commutated) can reduce the energy consumption.

This unit is quick and easy to install, and particularly simple to use.

EXPAIR CW

Cabinet supplied with chilled water.

EXPAIR DXA

Vertical self-contained unit with separate air condensation unit (CL2) (R410A).

ASSEMBLY

UNDER installation: reversed air supply

Installation 1

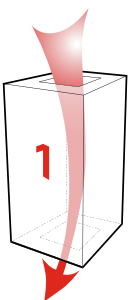

Air supply via raised floor

Installation 3

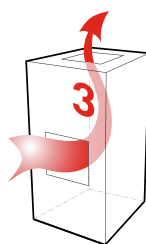

Front return

OVER installation: top air supply

Installation 4

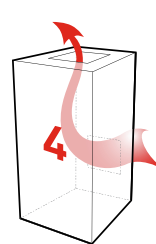

Rear return

Assembly 5

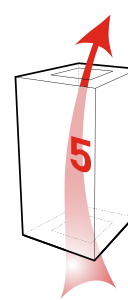

Return air below

RANGE

Units	CW	5	8	12	16		27					
	DXA	5	8	10	12	15	19	24	31	36	38	48
Nominal air flow rate (1)		1300	2000	2500	3000	4000	5000	6000	7000	8000	10000	12000
Associated CL2 condensation unit (2)		28	28	35	35	50	65	75	2x50	2x65	2x65	2x75

(1) Air flow adjustable via the controller.

(2) Two condensation units per close control unit for models 31 and 48.

QUICK SELECTION

EXPAIR CW

Units	CW 5	CW 8	CW 12	CW 16		CW 27	
Air flow rate (m ³ /h)	1300	2000	2500	3000	4000	5000	6000
*Maximum operating pressure with M5 (ePM10 50%) or F7 (ePm1: 60%) filtration	400	400	259	400	85	400	324
Total/sensible cooling capacity (kW)	5 / 4.8	8 / 7.6	10.5 / 9.9	14.7 / 13.2	18 / 16.7	23.5 / 21.5	27 / 25.1
Water flow rate (m ³ /h)	0,86	1,4	1,8	2,5	3,1	4	4,6
Pressure drop (mWC) (Coil + valve)	4,3	4,9	5,1	4,7	10	4,1	5,2

Specifications: total cooling capacity, pure water 7°C/12°C, air 24°C 45%. Pressure drop with control valve.

Cooling capacity for a maximum ΔT in air of 12°C.

* Maximum operating pressure dependent on air flow rate. Take off approximately 20 Pa if there is a hot water coil on EXPAIR.

The operation point can be adjusted directly via the controller. All air flow/operating pressure combinations are therefore possible.

Correction factors	7/12°C	10/15 °C	12/18 °C
22 °C/45%	0,84	0,58	0,44
24 °C/45%	1	0,74	0,5
30 °C/35%	1,48	1,18	0,9

EXPAIR DXA

Units	DXA 5	DXA 8	DXA 10	DXA 12	DXA 15	DXA 19	DXA 24	DXA 31	DXA 36	DXA 38	DXA 48
Air flow rate (m ³ /h)	1300	2000	2500	3000	4000	5000	6000	7000	8000	10000	12000
*Maximum operating pressure with M5 (ePM10 50%) or F7 (ePm1: 60%) filtration	400	400	276	400	89	400	324	273	26	330	21
Total/sensible cooling capacity (kW)	7.2 / 6	8 / 7.65	10.6 / 9.7	11 / 10.9	15 / 14.7	19 / 18.6	23.2 / 22.4	30.1 / 27.9	35 / 32	38 / 37.4	47 / 45.4

Specifications: total cooling capacity, air 24 °C 45%, 32 °C outdoor.

* Maximum operating pressure dependent on air flow rate. Take off approximately 20 Pa if there is a hot water coil on EXPAIR.

The operation point can be adjusted directly via the controller. All air flow/operating pressure combinations are therefore possible.

Correction factors	30 °C	32 °C	35 °C	40 °C
24 °C/50%	1,02	1	0,98	0,93
26 °C/50 %	1,06	1,04	1,02	0,98

Correction factors to apply to the cooling capacity based on the outdoor temperature and the return air conditions.

QUICK SELECTION

Hot water coil

Units	CW	5	8	12	16	27						
	DXA	5	8	10	12/15	19/24	31/36		38/48			
Air flow rate (m³/h)		1300	2000	2500	3000	4000	5000	6000	7000	8000	10000	12000
Heating capacity (kW)		4,5	6,2	7,5	11,9	13,7	17,8	19,5	25,8	27,6	37,5	40,9
Water flow rate (m³/h)		0,21	0,27	0,33	0,5	0,6	0,8	0,9	1,1	1,2	1,65	1,8
Pressure drop (mWC)		1,3	2,6	4,3	2,1	2,8	1	1,2	1,7	1,9	2,8	3,3

Specifications: heating capacity, air 20°C, pure water 80°C/60°C, pressure drop with control valve.

Correction factors to apply to the heating capacity for 90°C/70°C water temperature range: 1.23 and 45°C/35°C: 0.37.

2 stage or TRIAC electric heater, depending on the option selected

		CW 5	CW 8	CW 12	CW 16		CW 27					
		DXA 5	DXA 8	DXA 10	DXA 12	DXA 15	DXA 19	DXA 24	DXA 31	DXA 36	DXA 38	DXA 48
Total electrical power		3		6	9		12		18		24	
Electrical power (kW)	Stage 1	3			6		6		12		12	
	Stage 2	–	–	3	3		6		6		12	
Number of heaters	Stage 1	3 x 1 kW			3 x 2 kW		3 x 2 kW		3 x 4 kW		3 x 4 kW	
	Stage 2	–		3 x 1 kW	3 x 1 kW		3 x 2 kW		3 x 2 kW		3 x 4 kW	
Total current (A)		4,3		8,7	13		17,3		26		34,6	

DESCRIPTION

Casing

- Dual-wall construction.
- RAL 7035 grey precoated panel, removable:
 - 1 mm precoated exterior panels,
 - Glass wool, thickness 25 mm, class M0 (A2-s1),
 - 0.8 mm galvanised interior panels.

Filtration

- Filter cell efficiency ePM10 50% according to ISO16890 (M5 efficiency according to EN 779-2012).
- Optional filter efficiency ePM1: 60% according to ISO16890 (F7 efficiency according to EN 779-2012).
- Optional (except DXA 5/8/10 and CW 5/8/12) dual ePM10 50% + ePM1: 60% according to ISO16890 (M5 +F7 according to EN 779-2012).
- Filter cells tightly compressed against counter-frame by a gasket to ensure a completely leaktight seal.
- Fouling level monitored by an analogue pressure sensor.

Cooling coil cross-section

- Coil made of copper tubes, aluminium fins.
- Aluminium condensate drain pan.
- CW model with 2- or 3-way control valve fitted and connected. Optional thermally insulated flexible connections.
- DXA model with thermostatic expansion valve.

Ventilation section

- Direct drive centrifugal fan, associated with an electronically commutated (EC motor).
 - EC motor: fan adaptation via manual adjustment or "self-regulating" adjustment by the controller, depending on the room load - system air control.
- EC electric motor 1-Ph/230 V/50-60 Hz, 4-pole, class F.
- Air flow rate monitored by an analogue pressure sensor.

Electrics box for the indoor unit

Electrical power and control box consisting of:

- Power supply: 3-Ph/400 V/50 Hz+E+N.
- Emergency stop master switch.
- Protected transformer (three-phase, 400/24 V).
- Protection and control of fan motor, and of humidifier and electric heater depending on options selected.
- CIAT µAIR CONNECT2 control systems using PLC.
- Return air dry-bulb temperature control.
- Return humidity control:
 - Supply humidity control (optional)
 - Dehumidification humidity control (optional)
- Options available: standard water leak detection, fire thermostat and supply air low limit monitoring.
- Remote control and fault summary contact.
- Condensate drain pump (optional).

Accessories (option)

- Support base for air supply via raised floor.
- Supply plenum.
- Acoustic plenum with sound trap.
- Motorised damper on intake section.
- Fire thermostat.
- Hydraulic connection kit (chilled water and hot water coils).

Description of the outdoor unit (DXA model)

- CL2 type air condensation unit.
- Power supply: 3-Ph/400 V/50 Hz+E+N.
- SCROLL hermetic compressor.
- HP and LP safety pressure switches.
- Shut-off and control valves.
- 1 refrigerant circuit.
- Refrigerant fluid: R410A.
- Condensation pressure control by electronic board and pressure sensor. Variable speed control on condenser fan.
- Fault signal on indoor unit.

OPTIONS

Electric heater

- Fan-controlled operation.
- 2-stage control (except 3 kW electric heater).
- 2-stage or TRIAC control.
- Two high-limit safety thermostats with automatic and manual reset.

Hot water coil

- 1-row coil made of copper tubes with aluminium fins.
- 2- or 4-way control valve, fitted and connected.
- Optional flexible connections.

Humidifier

- Humidifier with immersed electrodes and a CPY board to relay all information relating to the humidifier directly to the CIAT μ AIR CONNECT2 PLC:
 - Stainless steel large surface area electrodes,
 - 3 kg steam per hour, for sizes CW5/8/12 and DXA5/8/10,
 - 8 kg steam per hour, for other sizes,
 - Steam cylinder in a single easy to remove component,
 - Filling solenoid valves,
 - Drain pump,
 - Electronics board for operation management,
 - Diffusion jet,
 - Water supply connection kit.
- Operates on municipal water supply only (water conductivity of between 350 and 1250 μ S and hardness 15 to 30 °F). Do not use deionised or softened water.

CONTROL

Unit control and monitoring

CIAT μ AIR CONNECT2



- 160-character display showing the operating instructions, operating states, faults and solutions. Configurable controller.
- Two fault levels.
- Monitoring of operating times.
- RS 485 output with Jbus/ModBus RTU protocol.
- Master/slave type management possible. (Backup, rotation and additions between the units).
- BACNET IP or MSTP gateways optional..
- Optional changeover thermostat (only on CW).

ELECTRICAL DATA

Indoor unit (CW and DXA models)

		CW 5	CW 8	CW 12	CW 16	CW 27			
		DXA 5	DXA 8	DXA 10	DXA 12/15	DXA 19/24	DXA 31/36	DXA 38/48	
Fan motor	Voltage (V)	230 V							
	Power (kW)	1,036		1,029		2,072	2,058	3,087	
	Current (A)	4,51		4,38		9,02	8,76	13,14	
Control circuit (transformer)	Voltage (V)	24 V							
	Current (A)	1							
Humidifier (option)	Voltage (V)	400							
	Power (kW)	2,25			6				
	Current (A)	3,2			8,7				
Electric heater (option)	Voltage (V)	400							
	Power (kW)	3	6	9	12	18	24		
	Current (A)	4,3	8,7	13	17,3	26	34,6		
Total current without option	Current (A)	5,51		5,38		10,2	9,76	14,14	
	Disconnect switch rating (A)	16							
Total current with humidifier	Current (A)	8,71			14,08		18,72	18,46	22,84
	Disconnect switch rating (A)	16				25			
Total current with electric heater	Current (A)	9,81	14,21	18,38	27,32	35,76	48,74		
	Disconnect switch rating (A)	16		25		40		63	
Total current all options	Current (A)	13,01		17,41		27,08	36,02	44,46	57,44
	Disconnect switch rating (A)	16		25		40		63	

Outdoor unit : Condensation unit (CL2) (DXA model)

Units	5	8	10	12	15	19	24	31	36	38	48	
Outdoor unit no./type	1x28	1x28	1x35	1x35	1x50	1x65	1x75	2x50	2x65	2x65	2x75	
Power supply no./type	3-Ph/400V/50Hz+E+N							3-Ph/400V/50Hz+E+N				
Max. total current (A)	7,5	7,5	9,0	9,0	11,3	17,0	17,0	2x11,3	2x17,0	2x17,0	2x17,0	

SOUND PRESSURE LEVEL

Indoor unit (CW and DXA models)

Units	CW	5	8	12	16	27						
	DXA	5	8	10	12/15	19/24	31/36	38/48				
Air flow rate (m³/h)		1300	2000	2500	3000	4000	5000	6000	7000	8000	10000	12000
Sound pressure level (dBA)		49	53	58	57	61	59	63	60	63	60	64

Sound pressure level of indoor unit (CW and DX) at 2 m in a free field, supply air connected, +/-3 dB.

Outdoor unit : Condensation unit (CL2) (DXA model)

DXA units	5	8	10	12	15	19	24	31	36	38	48
Models	28	28	35	35	50	65	75	2x50	2x65	2x65	2x75
Sound pressure level (dBA)	39	39	45	45	43	47	47	46	50	50	50

Sound pressure level of outdoor unit, at 5 m, 1.5 m from floor, in a free field, directivity 2 and +/-3 dB.

CONNECTIONS/WEIGHTS

Indoor unit

Units	Chilled water	CW 5	CW 8	CW 12	CW 16	CW 27		
	Direct expansion	DXA 5	DXA 8	DXA 10	DXA12/15	DXA19/24	DXA 31/36	DXA 38/48
Weight of indoor unit (kg)		115	120	125	280	310	375	480

Chilled water coil (CW)

Units chilled water	CW 5	CW 8	CW 12	CW 16	CW 27		
Inlet/outlet connections	G ½"M	G ¾"M	G ¾"M	G¾" M	G 1"M	G 1"M	G 1" ¼ M
Condensate draining*	Ø 32 mm						

Direct expansion coil (DXA)

Direct expansion units	DXA 5	DXA 8	DXA 10	DXA 12	DXA 15	DXA 19	DXA 24	DXA 31	DXA 36	DXA 38	DXA 48
Intake pipe	G 5/8"M	G 5/8"M	G 3/4"M	G 7/8"M	G 7/8"M	G1"1/8 M	G1"1/8 M	G 2X7/8" M	G 2X7/8" M	G 2X1"1/8 M	G 2X1"1/8 M
Liquid pipes	1/2"	1/2"	1/2"	1/2"	1/2"	1/2"	1/2"	2x1/2"	2x1/2"	2x1/2"	2x1/2"
Condensate draining*	Ø 32 mm										

Hot water coil

Units chilled water	CW 5	CW 8	CW 12	CW 16	CW 27		
Direct expansion units	DXA 5	DXA 8	DXA 10	DXA12/15	DXA19/24	DXA 31/36	DXA 38/48
Inlet/outlet connections	G ½" M	G ½" M	G ½" M	G ½" M	G ¾" M	G ¾" M	G ¾" M

Chilled water coil connections: inlet on threaded coupling and outlet on threaded control valve.

Condensate drain connection on smooth coupling.

* Drain connections if optional pump fitted: Diam. 6

Outdoor unit : Condensation unit (CL2)

Direct expansion units	DXA 5	DXA 8	DXA 10	DXA 12	DXA 15	DXA 19	DXA 24	DXA 31	DXA 36	DXA 38	DXA 48
Outdoor units no./type	1x28	1x28	1x35	1x35	1x50	1x65	1x75	2x50	2x65	2x65	2x75
Weight of outdoor unit (kg)	64	69	69	69	101	112	118	101	112	112	118

Refrigerant connections

Direct expansion units	DXA 5	DXA 8	DXA 10	DXA 12	DXA 15	DXA 19	DXA 24	DXA 31	DXA 36	DXA 38	DXA 48
Intake pipe	5/8"	5/8"	3/4"	3/4"	3/4"	7/8"	7/8"	2x3/4"	2x7/8"	2x7/8"	2x7/8"
Liquid pipes	3/8"	3/8"	3/8"	3/8"	3/8"	3/8"	1/2"	2x3/8"	2x3/8"	2x3/8"	2x1/2"
Condensate drain	Ø 32 mm										

DIMENSIONS

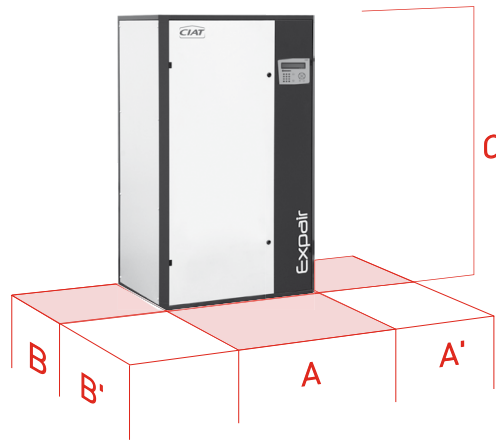

Indoor unit						
Units	Dimensions (mm)					Weight (kg)
	A	A'	B	B'	C	
CW5 DXA5	675	500	500	700	1700	115
CW8 DXA8	675	500	500	700	1700	120
CW12 DXA10	675	500	500	700	1700	125
CW16 DXA12/15	850	500	780	700	1900	280
CW27 DXA 19/24	1150	500	780	700	1900	310
DXA 31/36	1490	500	780	700	1900	375
DXA 38/48	1990	500	780	700	1900	480

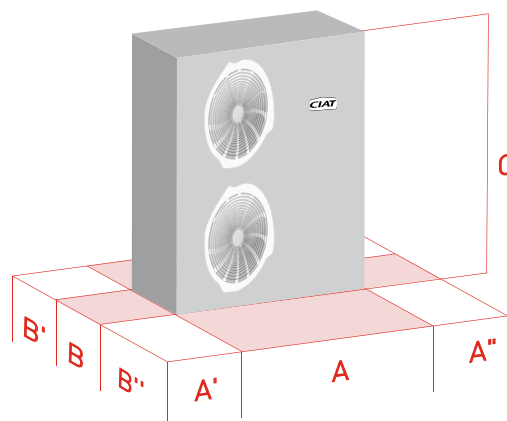

Outdoor unit (CL2)								
Models	Dimensions (mm)							Weight (kg)
	A	A'	A''	B	B'	B''	C	
28	1035	150	1000	450	150	1500	732	69
35	1035	150	1000	450	150	1500	732	69
50	1035	150	1000	450	150	1500	1332	101
65	1035	150	1000	450	150	1500	1332	112
75	1035	150	1000	450	150	1500	1332	118

DIMENSIONS

Indoor unit (CW and DXA models)

■ Fitting UNDER 1

CW 5/8/12
DXA 5/8/10

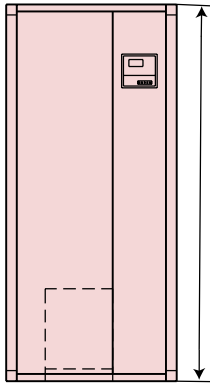

1700

CW 16
DXA 12/15

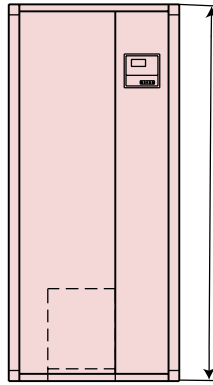

1900

CW27
DXA 19/24

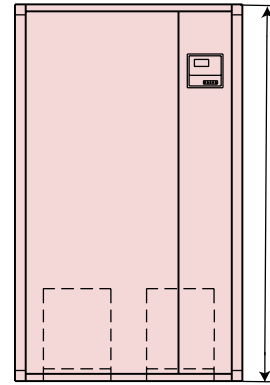

1900

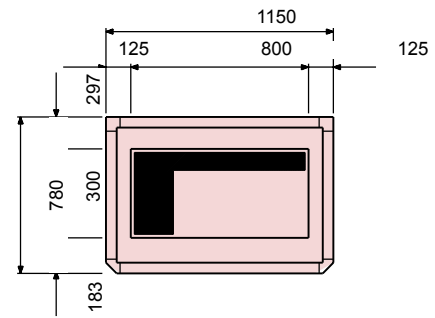
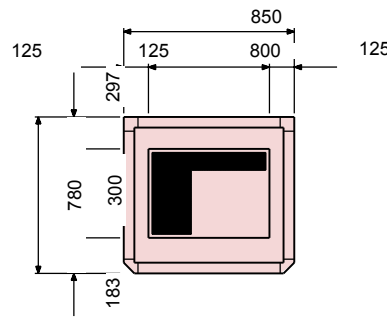
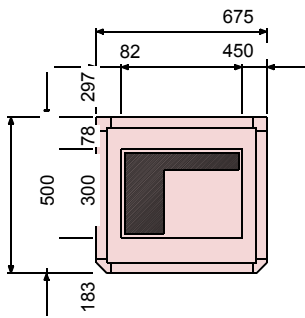

DXA 31/36

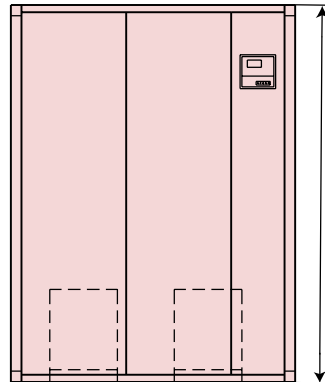

1900

DXA 38/48

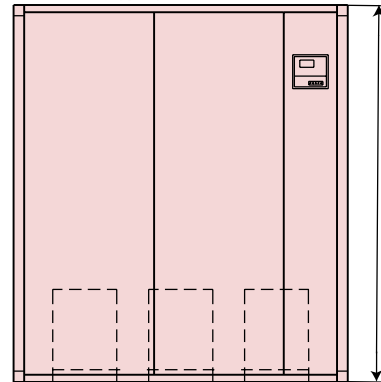

1900

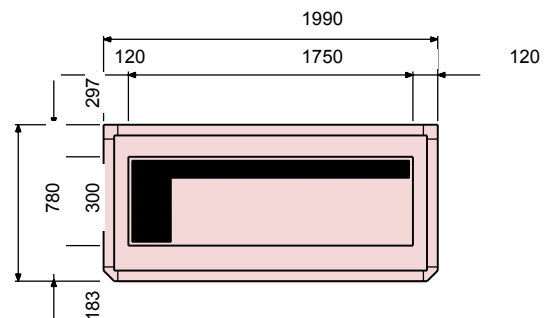
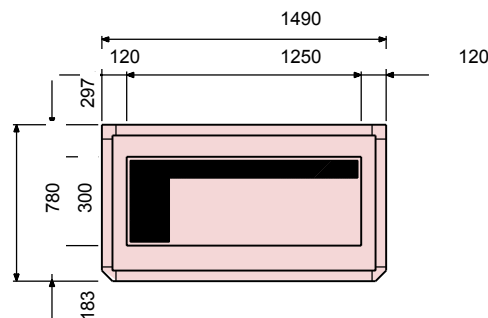

DIMENSIONS

Indoor unit (CW and DXA models)

■ Fitting OVER 3

**CW 5/8/12
DXA 5/8/10**

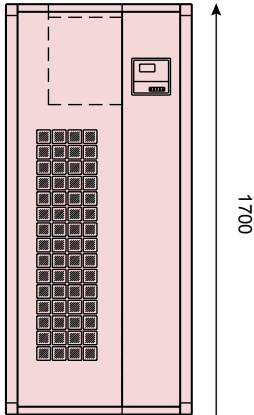

**CW 16
DXA 12/15**

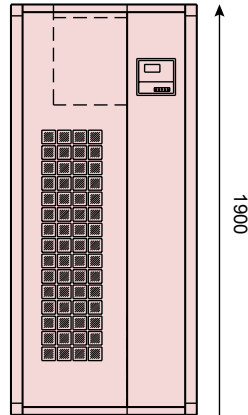

**CW 27
DXA 19/24**

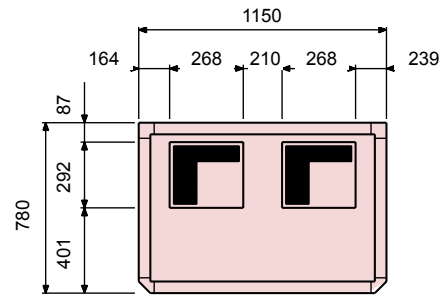
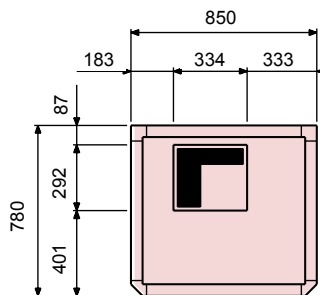
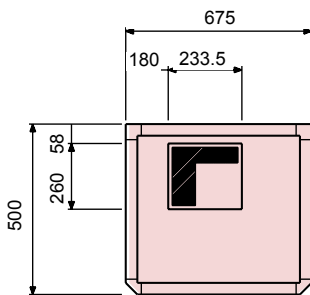
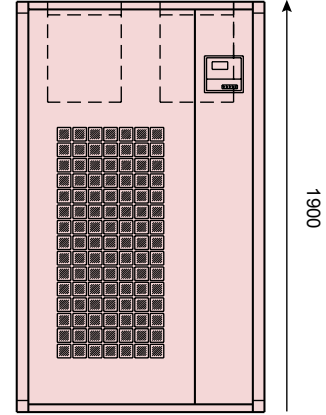

DXA 31/36

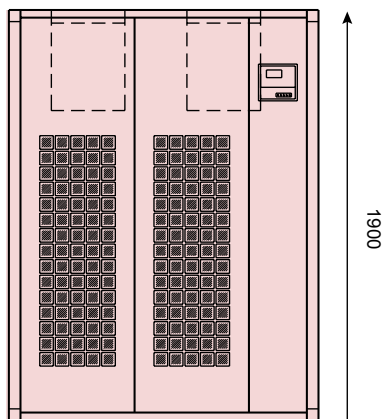

DXA 38/48

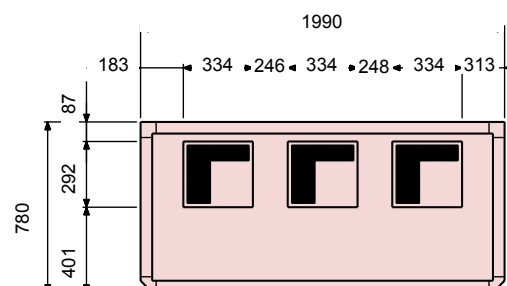
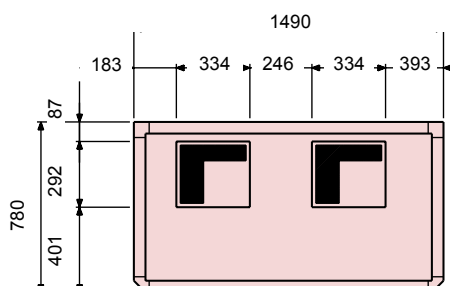
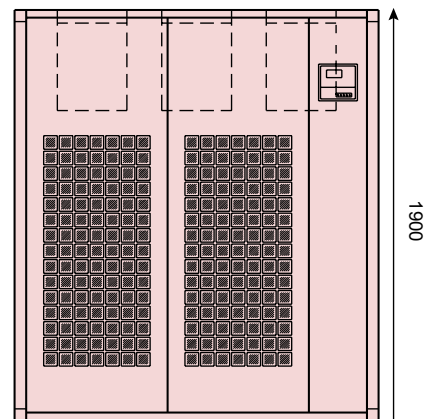

DIMENSIONS

Indoor unit (CW and DXA models)

■ Fitting OVER 4

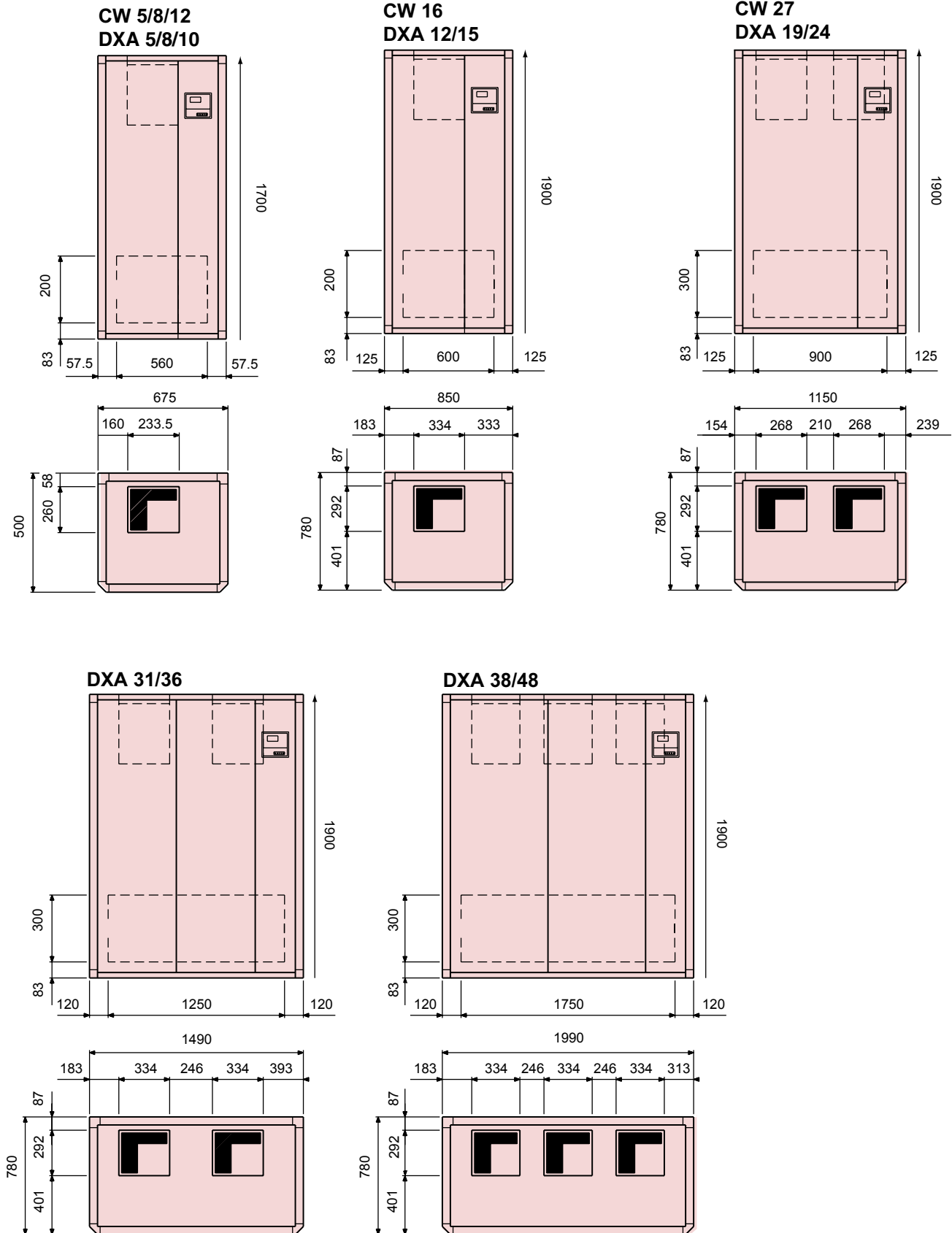

DIMENSIONS

Indoor unit (CW and DXA models)

■ Fitting OVER 5

**CW 5/8/12
DXA 5/8/10**

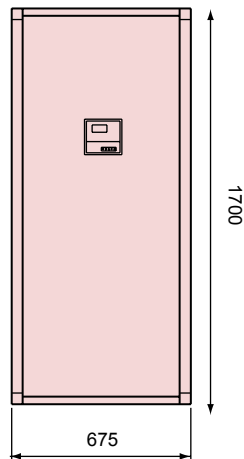

**CW 27
DXA 19/24**

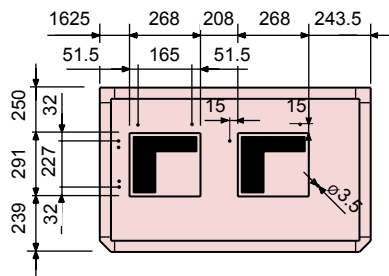
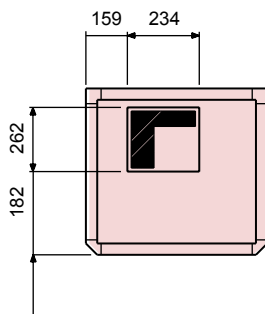
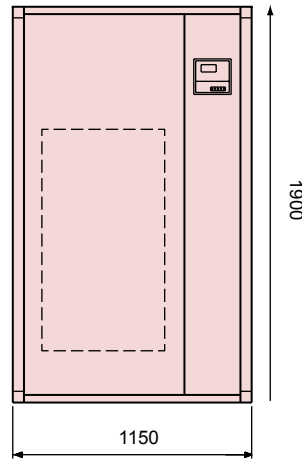

DXA 31/36

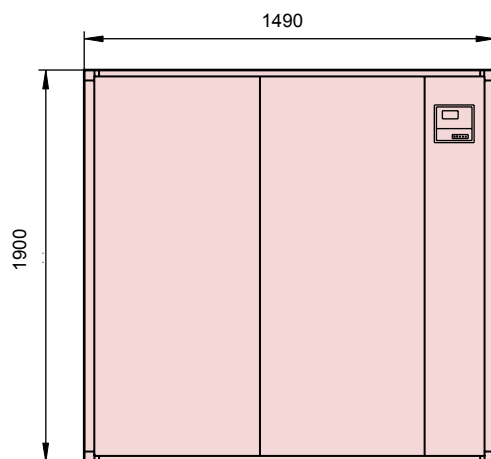

DXA 38/48

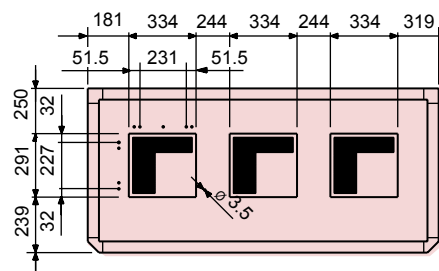
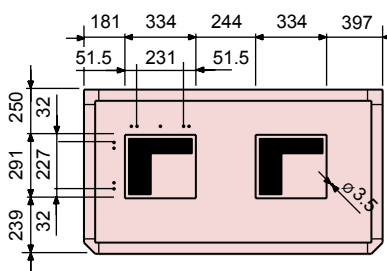
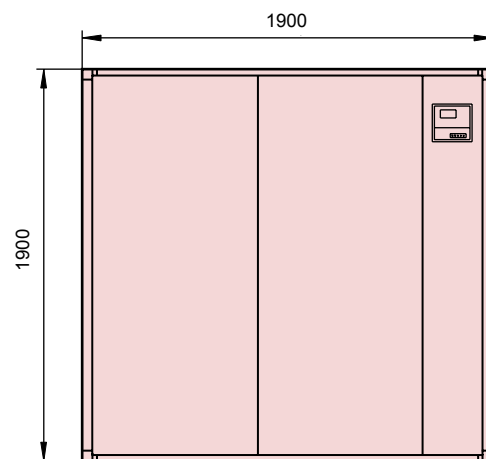

DIMENSIONS

Outdoor unit (CL2)

■ Models 28 and 35

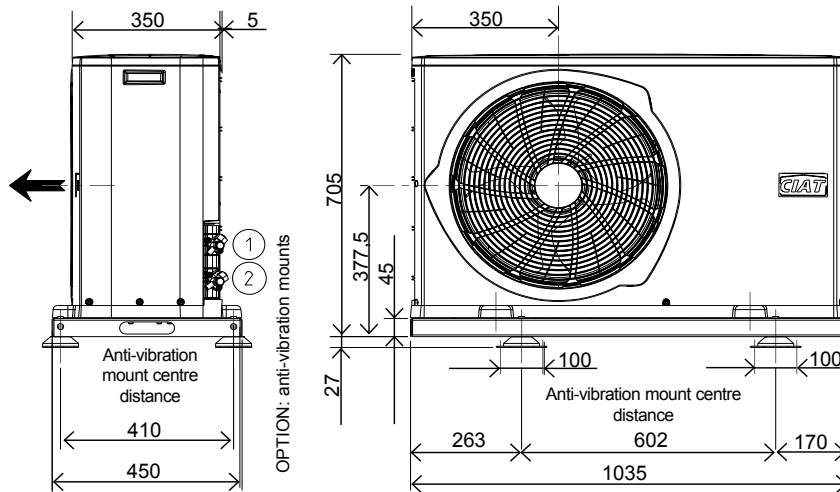

■ Models 50 65 and 75

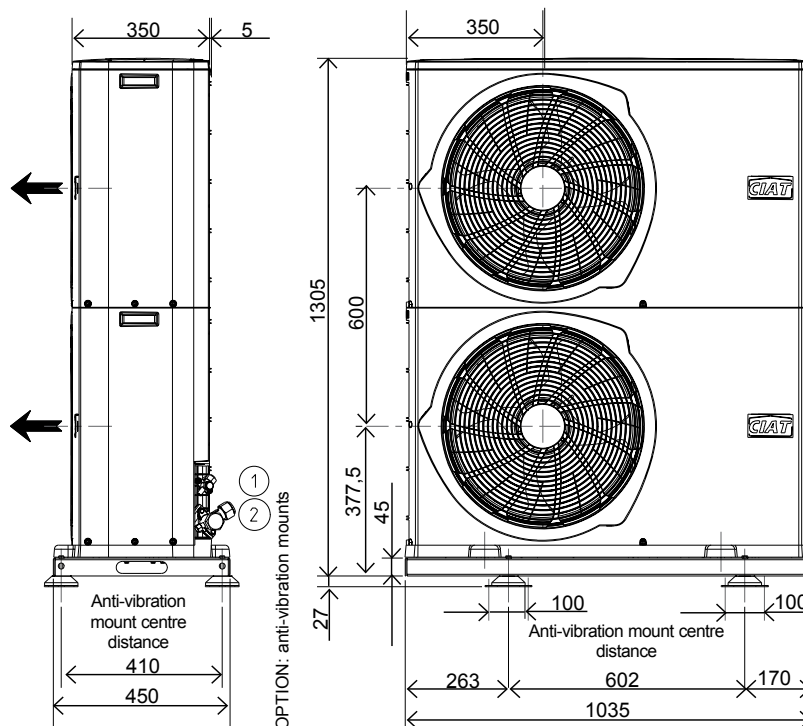

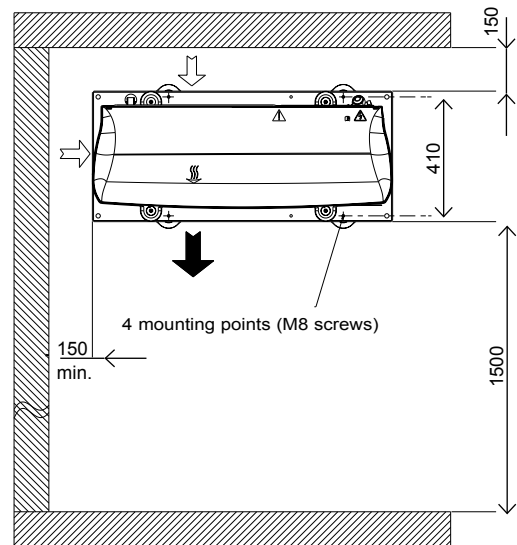
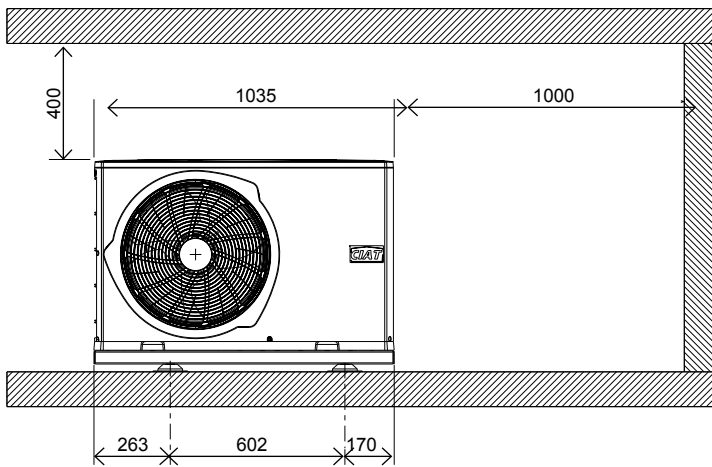
INSTALLATION (IN MM)

Installation on soft ground

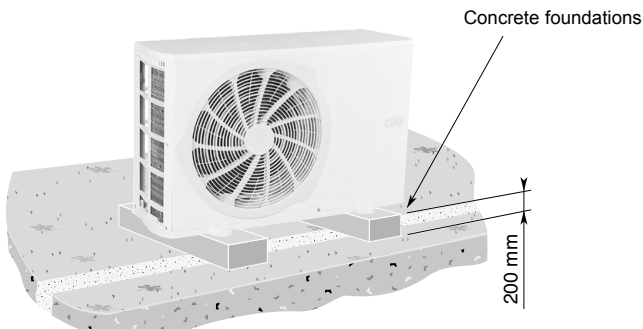

Installation on concrete ground

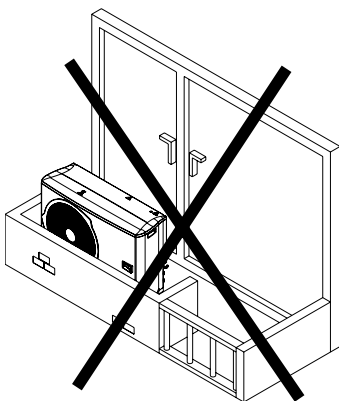
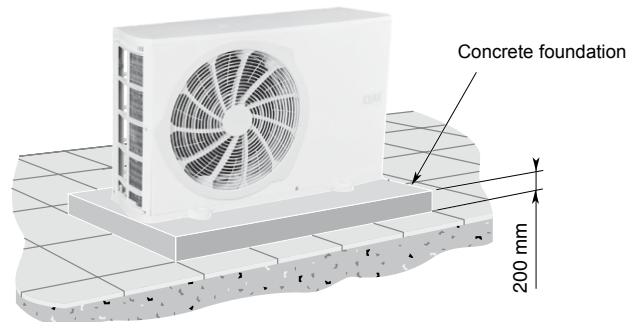

Nothing should obstruct the free flow of air over the air-cooled exchanger. Adhere to the minimum distances shown above.

Protect from prevailing winds.

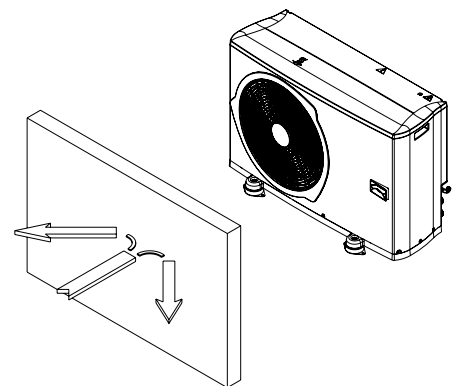

- The outdoor unit (CL2) must be installed outdoors, either on a patio or in a garden. It has been designed to operate in all weathers, including adverse conditions, but can also be placed under a shelter open on all four sides.
- The unit should ideally be positioned facing north or in the shade, to keep the condenser coil out of bright sunlight.
- Do not place objects over the fan's air supply and return. There should be nothing obstructing the coil's air intake.

OPERATING LIMITS

Chilled water (CW)

Water circuit	Maximum pressure: PN16	Minimum water inlet temperature: 5 °C (consult us for other values)
		Maximum water inlet temperature: 80 °C (consult us for other values)
Indoor temperature		Minimum air inlet temperature: 12 °C, and according to return humidity
		Maximum air inlet temperature: 45 °C and according to return humidity (Weight in water, condensed < 0.8 g of water/kg of dry air)
Power supply		3PH / 400V + E + N

Direct expansion (DXA)

Indoor temperature		Minimum air inlet temperature: 18 °C, and according to return humidity
		Maximum air inlet temperature: 28 °C, and according to return humidity (Weight in water, condensed < 0.8 g of water/kg of dry air)
Outdoor temperature		Minimum air inlet temperature: -15 °C
		Maximum air inlet temperature: 45 °C
Power supply	Indoor unit	3PH / 400V + E + N
	Outdoor unit(s)	3PH / 400V + E + N

This document is not legally binding. As part of its continuous drive to improve its equipment, CIAT reserves the right to make any technical modifications without prior notice.
Ref.: NA.20.616A

Siège social (Head office)

700 Avenue Jean Falconnier - B.P. 14
01350 - Culoz - France
Tel.: +33 (0)4 79 42 42 42
Fax: +33 (0)4 79 42 42 10
www.ciat.com

