

## COADIS LINE 600

Comfort units  
COANDA effect cassette

*COADIS LINE 600*  
**the new generation**  
**of cassette comfort units**  
*Innovative casing (Flexiway concept)*  
*integrates perfectly into suspended ceilings*  
**Air purification system**

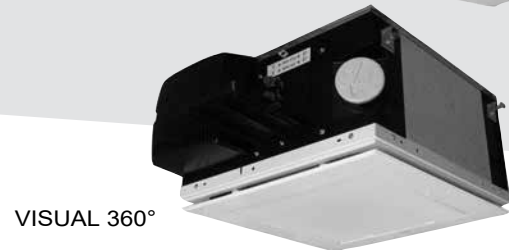

Cooling capacity: 1 kW to 6 kW  
Heating capacity: 2 to 10 kW



### COADIS LINE, INNOVATION AHEAD OF ITS TIME...

- CIAT has once again exceeded the established standards by offering increasingly innovative products in terms of environmental protection, while ensuring the user remains the key concern.
- Combining energy efficiency, comfort and indoor air quality, the **COADIS LINE** is the all-in-one solution designed to meet the heating and cooling requirements of tertiary buildings, while offering users maximum comfort.
- An active, variable-speed comfort unit offering high energy efficiency (HEE system), it allows the indoor temperature to be autonomously and independently adapted over very short periods to ensure the comfort of occupants.
- The EPURE function (air purification system) ensures an exceptionally high quality of indoor air by maintaining the concentration of PM 2.5 particles below the threshold recommended by the WHO ( $10\mu\text{g}/\text{m}^3$ ).
- Thanks to its single-size casing, the COADIS LINE can be fitted with 180° and 360° diffusion in order to suit different building layouts (FLEXIWAY concept).
- The Coanda effect diffusion has been redesigned and optimised in accordance with standard NF EN ISO 7730, guaranteeing optimal management of thermal phenomena which create discomfort. In addition, the COADIS LINE eliminates the sensation of draughts that can occur with sweeping diffusion systems or those supplying air directly to the occupants.
- The innovative casing of the COADIS LINE - an eco-designed product which is 90% recyclable - reduces the environmental impact throughout the duration of its life cycle.

## RANGE

The range of COADIS LINE 600 cassettes features 7 sizes covering flow rates from 250 to 770 m<sup>3</sup>/h, and meeting the most stringent sound level requirements.

→ 2 diffusion models

- Visual 180 °: Coanda effect diffuser across 180 °
- Visual 360°: Coanda effect diffuser across 360 °

→ The COADIS LINE is available as:

- A 2-pipe system, with heating or cooling mode
- A 2-pipe + 2-wire system, with cooling + heating/cooling + electric mode.
- A 4-pipe system, with heating and cooling mode.

## ADVANTAGES

- Uses an ecological and long-lasting heat-transfer fluid.
- Individual adaptation of the indoor temperature.
- Responsiveness of the system.
- Extensive capacity range.
- Diffusion by Coanda effect across 180 ° or 360 ° for comprehensive coverage, and perfect control of thermal phenomena which cause discomfort.
- Acoustic comfort.
- Optimum indoor air quality thanks to the EPURE function.
- Energy optimisation:
  - High Energy Efficiency motor
  - Epure filter.
  - Optimised hydraulic coil.
- Modularity for indoor spaces (Flexiway).
- Condensate drain by gravity avoiding the need for a drain pump.
- Modern, elegant design to ensure perfect integration.
- Environmentally-responsible product.
- Ease of maintenance.

## INNOVATIVE DESIGN

- New-generation casing combining high-density PSE integrating combined thermal and acoustic functionalities, ABS PC and a ribbed galvanised steel base panel to stiffen the assembly.
- Single-size casing for all unit sizes with base adapted to 600 x 600 mm suspended ceiling framework.
- Hydraulic, air and electrical connections on the same side for easier mounting, access and maintenance.
- Hygienic supply of fresh air with 100 mm diameter sleeve integrated directly in the casing with removable plug.



## FUNCTION



The air we breathe is full of fine particles which enter the respiratory system to varying degrees.

The EPURE function (air purification system) exceeds the WHO's recommendations on particle removal, reducing PM2.5 particulates to below 10 µg/m<sup>3</sup> in less than an hour. This is equivalent to a reduction of 50% to 90% in particulate matter.

**Epure** is the combination of all the components that make up the COADIS LINE:

- A protected stream of air that is free of particulates present in suspended ceilings,
- Optimised air diffusion over 180 ° or 360 ° using the Coanda effect and a suitable mixing rate to ensure uniform treatment of the room,
- Very high-efficiency local room-by-room filtration of PM2.5 fine particles,
- Filter area x10.

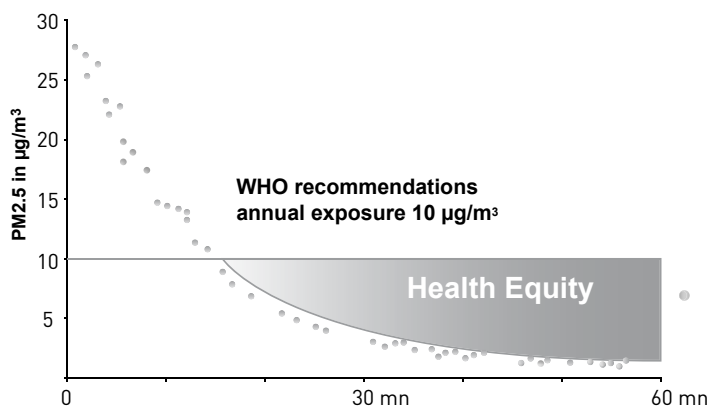

## THE COANDA EFFECT

VISUAL Coanda effect diffuser:

The single slot peripheral outlet with its narrow opening and specific internal profile will increase the initial speed of the air as it leaves the diffuser. The high speed of the moving flow of air causes an area of low pressure which keeps it close to the ceiling, (there is no direct blast on occupants) and the ambient air is drawn in by induction to be reinjected in the air stream. The air mix rate, the range and the coverage of the air flow are improved, which reduces thermal phenomena that cause discomfort in the occupied area (residual air flow rate, asymmetric temperatures, radiation caused by walls, etc.).

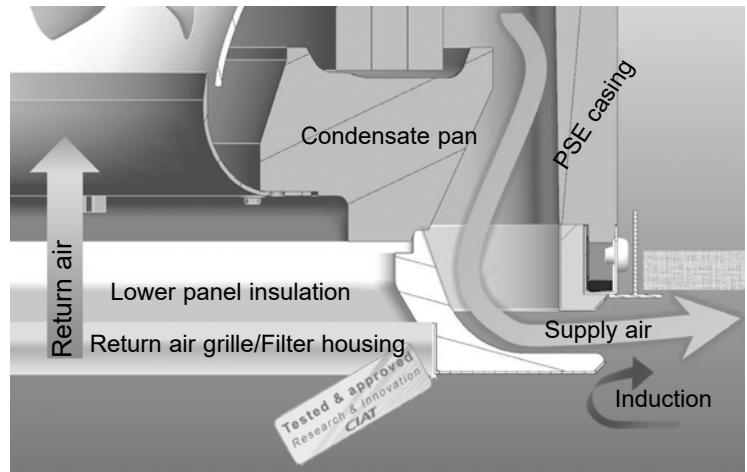

## COOL AIR FALL PREVENTION SYSTEM

The new 180° diffusers are equipped with an "anti-cold shower" system which guarantees maximum comfort by preventing air from falling between two cassettes.

The system is specially designed by our Research and Innovation centre; two deflectors integrated in the insulation enable the air stream from the lateral channels to be slightly redirected. When the units are placed side by side in the same room, the air flows do not oppose one another and cross over in parallel, which avoids any cold air draughts.

This patented system removes the discomfort caused by draughts without having to reduce the outlets and with no increased noise levels, while maintaining the air flow necessary for the thermal requirements.

## MODULARITY AND VISUAL COMFORT

To ensure perfect visual integration within your building, the FLEXIWAY concept offers two Coanda effect single-vent diffusion systems (Visual 180° and 360°), interchangeable on site, suitable for partitioned offices and open plan spaces.

Designed in close collaboration with both architects and designers, each interface, in RAL 9010 white painted steel, will integrate perfectly into suspended ceiling tiles.

### FLEXIWAY

Offers greater flexibility when modifying indoor partitioned spaces, in order to reduce operational costs. Enables optimal adaptation to the new configuration (offices or open spaces) without the need to replace the comfort unit. Based on a casing with a single format, Flexiway means that units already in place can be quickly switched for Visual 180° and 360° diffusers, which can be positioned in any direction thanks to their symmetrical mounting points. If the site to be altered only has a single diffuser model, it is possible to order the model of your choice which is supplied separately in its protective packaging.

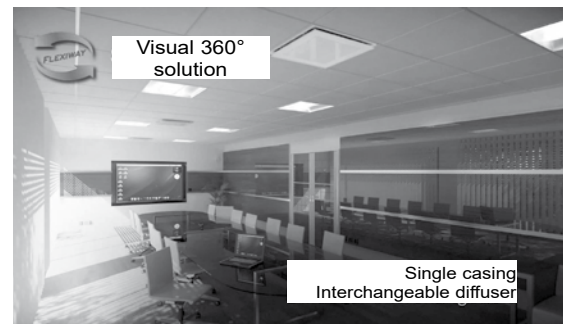
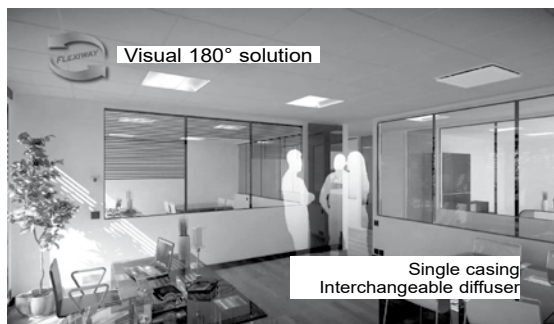

Perfect for new buildings, harmonising enclosed and open plan spaces. The Visual 180° solution is particularly suited to partitioned spaces from 10 to 20 m<sup>2</sup>, with the unit positioned at the edge of the room. The Visual 360° solution is ideal for open plan areas with the unit positioned centrally.

The diffusion panels, which are delivered individually packaged, allow the unit to be installed easily without the risk of damaging or soiling the visible part.

## COMPLIANCE WITH ENERGY REQUIREMENTS

- Exchanger coils specially developed to meet the requirements of low energy buildings.
- Exchanger coils optimised to reduce costs and consumption associated with other components in the installation.
- HEE motor (high energy efficiency) using Brushless technology.
- Reduced-power electric heating coils to better meet the requirements of new buildings.

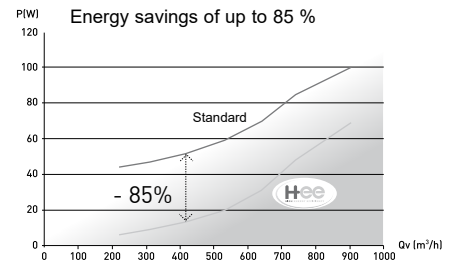

## ECO-DESIGN

### Raw materials

- Weight reduced by 30 % and volume by 21 % thanks to compact, carefully designed architecture.
- Use of easily recyclable materials (EPS and ABS).

### Transport

- Raw material suppliers selected from those that are less than 100 km from our manufacturing and packaging factory, enabling a 50 % gain in volumes transported (reduction in CO<sub>2</sub> emissions).

### Recycling and ease of disassembly

- 90 % recyclable products.
- Total material separability and 40 % reduction in the number of mountings for efficient processing by recycling companies.



## EASE OF INSTALLATION AND OPERATION

COADIS LINE has been designed to facilitate installation and reduce on-site interventions:

- Fitting template provided with each unit to mark out the anchoring points on the ceiling.
- Optimised weight and size to facilitate handling during installation.
- Mounting brackets equipped with anti-slip system to hold the threaded rods when attaching and levelling the unit.
- Safety lock enabling the diffuser to be left hanging, leaving the hands free during the mounting screw tightening phase.

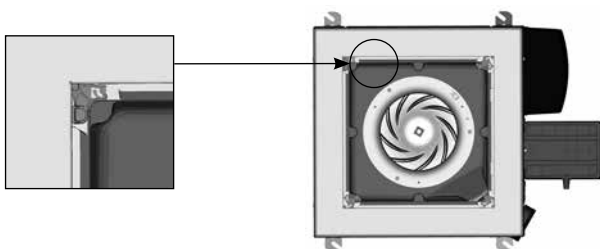

- Technical panel with all connections (electrical, air and hydraulic) on one face.
- Hygienic fresh air supply sleeve with plug integrated directly in the casing (no installation necessary).
- Large electrics box with single closure point containing all the controller kits (quick fit plate with prewired electrical bundle) in the CIAT range.
- Internal components can be accessed without the need to remove the suspended ceiling tiles, via the quick-release filter door grille mounted on retaining hinges for greater freedom of movement during interventions.

## OVERVIEW

The air handling box is fitted inside the suspended ceiling at the edge of the room with the supply air opposite windows and the electric box facing the interior of the building for models with a Visual 180° return/diffusion panel. For Visual 360° models, position the box in the centre of the room with the electric box facing the interior of the building. Leave a minimum space of 300 mm to 600 mm at the rear of the unit to allow access to all of the air, electrical and hydraulic connections.

The COADIS LINE must be suspended from the ceiling using four 6 mm or 8 mm threaded rods (not supplied) to be fixed to the four unit mounting brackets with the anti-vibration resilient mounts or a nut/washer assembly positioned either side of the mounting bracket.



### Mounting principle 2 methods

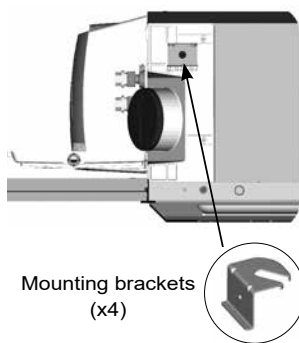

Attached using  
4 threaded rods  
(6mm or 8mm)

Elastic  
damper

Nut/washer assembly  
placed either side  
of the mounting  
bracket

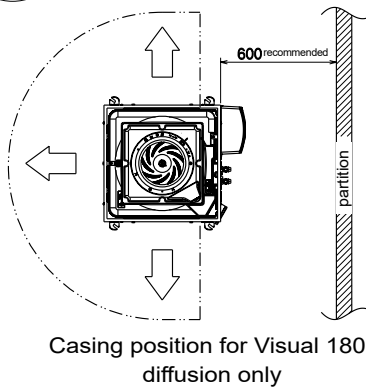

Mounting system for Visual diffusers with  
4 captive screws

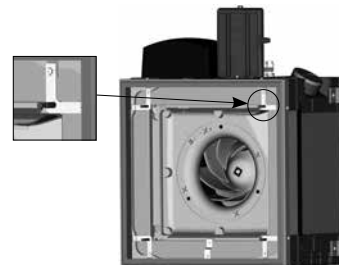

## FRESH AIR INLET SPIGOT

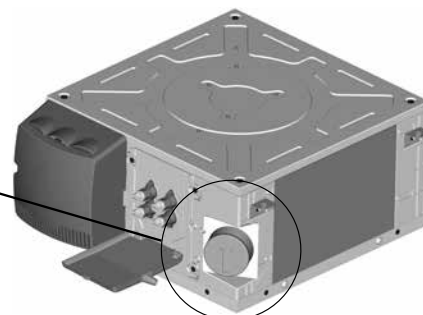
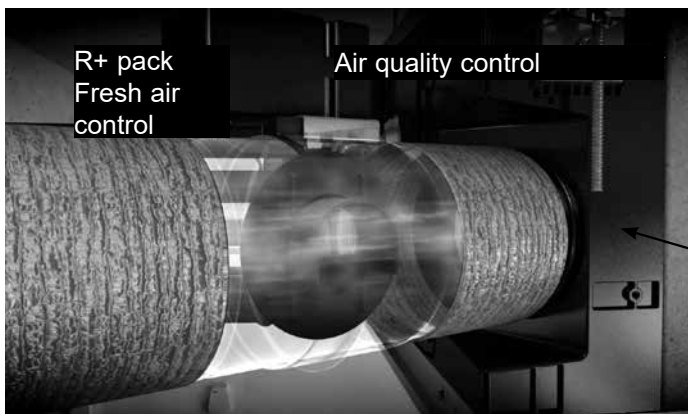

Ø 100 mm collar, max. air flow 90 m<sup>3</sup>/hr recommended.  
Network balancing system (not supplied by CIAT)

### IAQ pack

- For offices, air quality control with presence sensor (R1 pack),
- For meeting rooms, air quality control with CO<sub>2</sub> sensor (R+ pack).

## COADIS LINE 600 MORPHO-DESCRIPTIVE CODE

Range	Size	Model	Coil type	Thermal function		Motor	Speeds	Filter
CDL	622	V360°	2T2W	F	+ 1200 W	HEE	depending on selection	EP

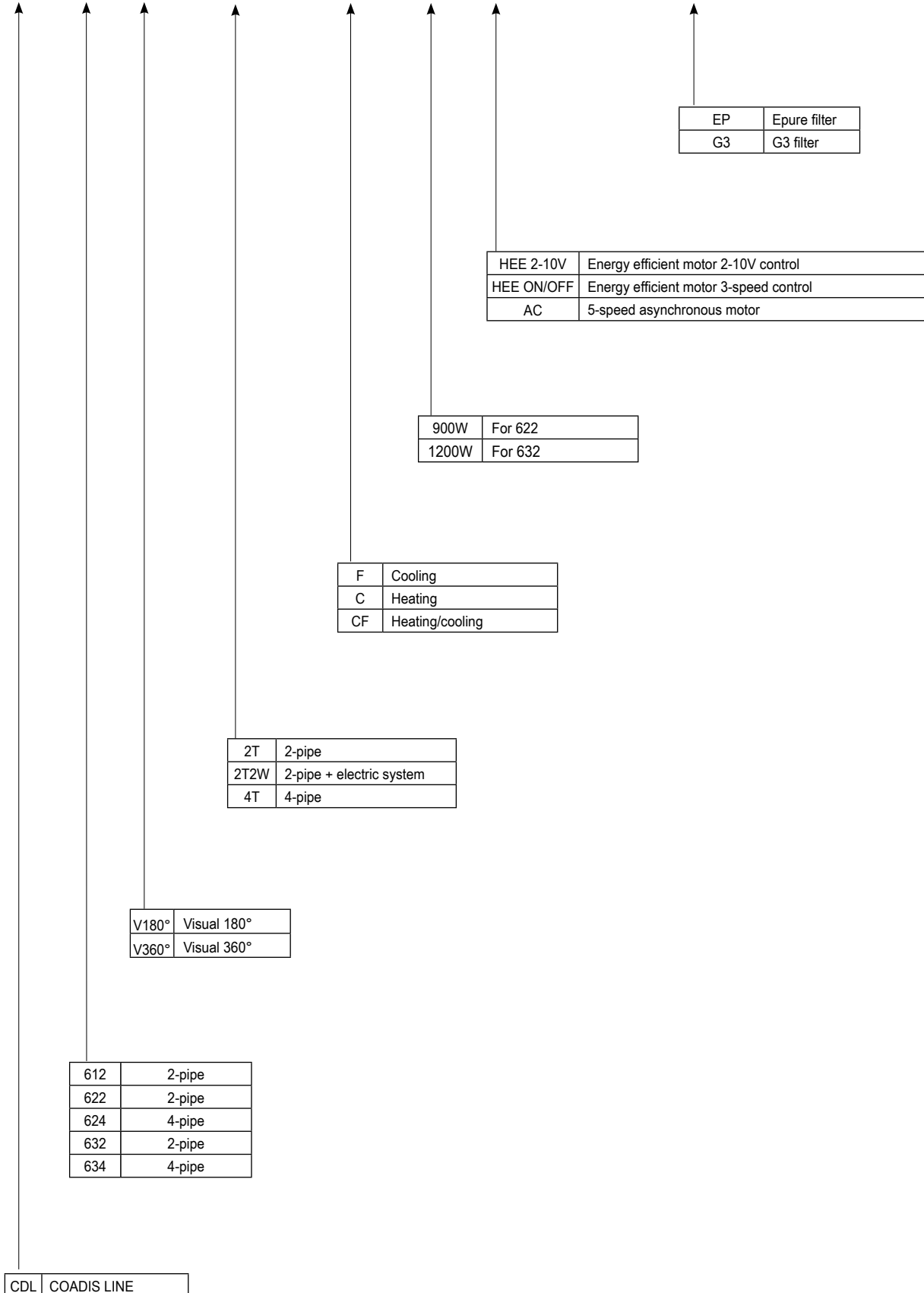

## TECHNICAL DESCRIPTION

### Return/supply air interface

**VISUAL interfaces: Coanda effect diffusion via a single narrow opening vent and specific internal profile.**

- 2 models available: Visual 180 ° or 360 °.
- In sheet metal painted in RAL 9010 to be fitted over the chassis and exactly the same dimensions as a standard suspended ceiling tile.
- Micro-perforated hinge-mounted metal return air grille with housing for EPURE function filter, opens fully without tools.
- PSE insulation, M1 fire resistance with very low heat transfer coefficient.
- An "anti-cold shower" system which is patented (filed under No. 1451872) which prevents air from falling between the two cassettes when they are aligned around the edges of the room (only with Visual 180 ° diffuser).

### Casing

- Single casing and reduced size for all unit sizes, fits in place of a 600 x 600 mm or 675 x 675 mm suspended ceiling tile (option).
- Reduced weight compared to the previous generation cassette.
- Ribbed galvanised steel motor support base panel, 10/10th thick.
- High-density PSE casing integrating thermal and acoustic functionalities. 15 mm base and 25 mm to 30 mm thick vertical sides that make up the enclosure.
- Low emission of TVOCs and no halogenated compounds.
- ABS corner reinforcements fitted with open galvanised one-way steel mounting brackets for assembly of threaded rods.
- Fire rating: M1.
- Hydraulic, air and electrical connections on the same side of the technical panel at the rear of the unit providing a single access point.
- Finish frame in RAL 9010 galvanised steel, 8/10th thick, housing the diffusion interface.
- Centring of the unit between the suspended ceiling profiles using anti-vibration elastomer mounts fitted on the finish frame.

### Water coil

- 1 hot or cold water circuit (2-pipe system).
- 1 hot water circuit + 1 cold water circuit (4-pipe system).
- Single piece sleeve with 40 mm centre to centre distance with integrated sealed flush fitting female revolving unions, for easy fitting of the control valves.
- Low pressure drop one, two, or three layer circular coils.
- Copper pipes, one-piece aluminium fins (1.6 mm pitch).
- Purge and drain.
- Rated pressure 16 bar (at 20°C).
- Test pressure 24 bar.
- Max. hot water inlet temperature:
  - 4-pipe application: 80 °C,
  - 2-pipe application: 70 °C,
  - 2-pipe/2-wire application: 55°C (min air flow rate: 200m<sup>3</sup>/h).
- Min cold water inlet temperature: 6°C.

### Electrical heater (2-pipe + electric system)

- 230V/150 single-pipe electrical elements inserted into the aluminium housing.
- 2 temperature limiters, manually and automatically reset, inserted in the aluminium block with easy access that does not require the suspended ceiling to be opened, via the Intake / outlet interface.

- Heater element feed on the terminal block inside the electrics box.
- It is possible to deactivate a heater element on site by means of a shunt on the terminal to reduce the electrical power.

### Condensate drain pan

- Single unit main pan in high-density sealed PSE for use in all climates, naturally sloped and removable from below without the need to open the suspended ceiling.
- Fire rating: M1.
- ABS PC auxiliary pan with no water retention provided as an accessory for the recovery of condensates from the valves and coming from the main pan.
- Gravity drain: height 70 mm.
- Drainage bushing: external Ø 15 to 20 mm.

### Fan motor assembly

#### ■ HEE motor

**Low energy motor making it possible to reduce electrical consumption by up to 85%.**

- Brushless technology.
- Sealed type, tropicalised with protected shaft.
- 3-speed gradual operation by 0-10V or on/off control signal, without expansion board.
- Internal normally closed series automatic overload protection on the windings.
- "DFS" motor fault output using a photocoupler for potential alarm feedback via a Konnex protocol communication bus (via the V3000 controller).
- Mounted on anti-vibration mounts.
- 230 V/1-Ph/50 Hz feed (60 Hz compatible).

**Note:** The minimum voltage to start up the motor is 2 V.

Or

#### ■ Asynchronous motor

5 factory-wired speeds connected to a terminal strip for customisation.

- Sealed type, tropicalised with protected shaft.
- Permanent capacitor.
- Roller bearings.
- Internal normally closed series automatic overload protection on the windings.
- Resilient mounts.
- 230 V/1-Ph/50 Hz feed (60 Hz compatible).
- High output and Displacement Power Factor (Cos Phi).

#### ■ Fan(s)

- Balanced centrifugal turbine Ø 282 mm with profiled blades.
- Polymer turbine.
- Single point mounting system with foolproofing device.

### Electrics box

- Large ABS electrics box with supported hinge and closed with a bolt.
- IP20 Index of Protection.
- Electrical connection terminal on DIN rail in compliance with EN 50022, 7.5 mm deep.
- Marked out terminal strip with spring connectors. 0.5 to 2.5 mm<sup>2</sup> cross section - Max. current: 24 A – Shock resistance: 8 kV. Cable grommet for field connection.

### Fresh air supply sleeve

Connection sleeve for fresh air inlet, Ø100 mm, integral to the frame with removable plug.

## Air filter

- Epure function for superior indoor air quality.
- A protected air stream which prevents particles from being drawn into suspended ceilings.
- Uniform treatment of the room thanks to optimised diffusion over 180° or 360° using the Coanda effect.
- Suitable mixing rate.
- Local filtration by high efficiency filter medium effective on fine particles up to 2.5 microns.
- Filter area 10 times greater than the intake grille surface.
- No discharge from the filter during replacement thanks to the folded filter medium with heat-sealed lateral inserts to make it more rigid.
- Improved service life compared to a conventional flat filter, thanks to its high retention capacity.
- Low energy impact. Fire rating: M1.
- No release of glass fibres.
- 100% incinerable at end of life.

## Device mounting

Open mounting brackets, factory-fitted, made from galvanised steel, 15/10th thick, with check valve for securing the threaded rods during fitting and levelling.

## Packaging

- Strapped cardboard crate for the casing.
- Fitting template and direction of fitting printed on the cardboard.
- Visual return/supply air interface supplied separately in protective cardboard packaging.
- Delivered on film wrapped pallet from the factory.

## Controls

- RTR-E electromechanical thermostat range
- V30 electronic range
- V300 electronic range
- V3000 networked electronic range (KNX)
- Networked electronic range (LON): V-LON2

## Options (factory-fitted)

- Hydraulic coil with protected blades for aggressive / corrosive areas (locations close to the sea or with chemical industries located close by).
- Condensate drain pump.
- G3 filter.
- Extension.
- Finishing trim frame for 675 x 675 mm suspended ceiling tiles.
- Finishing trim frame for STAFF ceilings.

## Accessories (available separately)

- Anti-vibration resilient mounts for mounting brackets.
- Self-regulating conditioned fresh air inlet module (3 flow rates adjustable using a set of shims).
- Ø 100-125 mm sleeve adapter.
- Condensate drain pump kit with high safety device.
- 230 V thermo valve kit.
- Prewired controller kit mounted on the plate.
- 80 mm riser kit for gravity drainage without condensate drain pump.
- Finish counter frame kit for 675 mm suspended ceiling tile.
- 300 mm connecting hose kit with or without 9 mm insulation.
- Fresh air pack:
  - R1: Fresh air managed via presence sensor.
  - R+: Fresh air management via CO<sub>2</sub> sensor (max. air flow 90 m<sup>3</sup>/h recommended, network balancing system not supplied by CIAT).
- Speed control unit kit for HEE motors with 3-speed on/off control.



## INTEGRATION INTO THE SUSPENDED CEILING

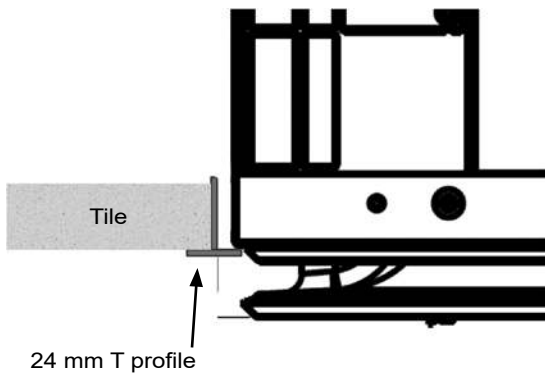

24 mm T profile  
Mounting position with 600 x 600 mm suspended ceiling on T profile

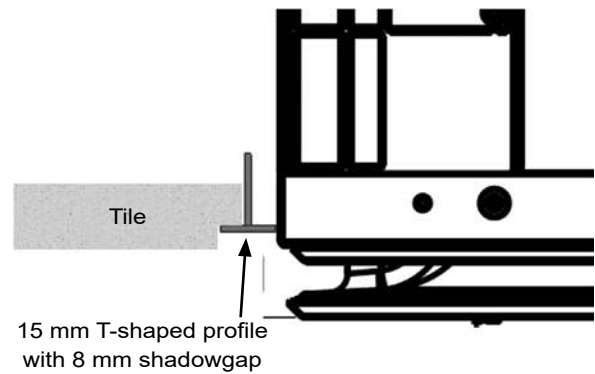

15 mm T-shaped profile with 8 mm shadowgap  
Mounting position with 600 x 600 mm suspended ceiling on T profile with 8 mm shadowgap

**Note:** not compatible with steel tray suspended ceilings and clip-in type mountings.

## DIMENSIONS

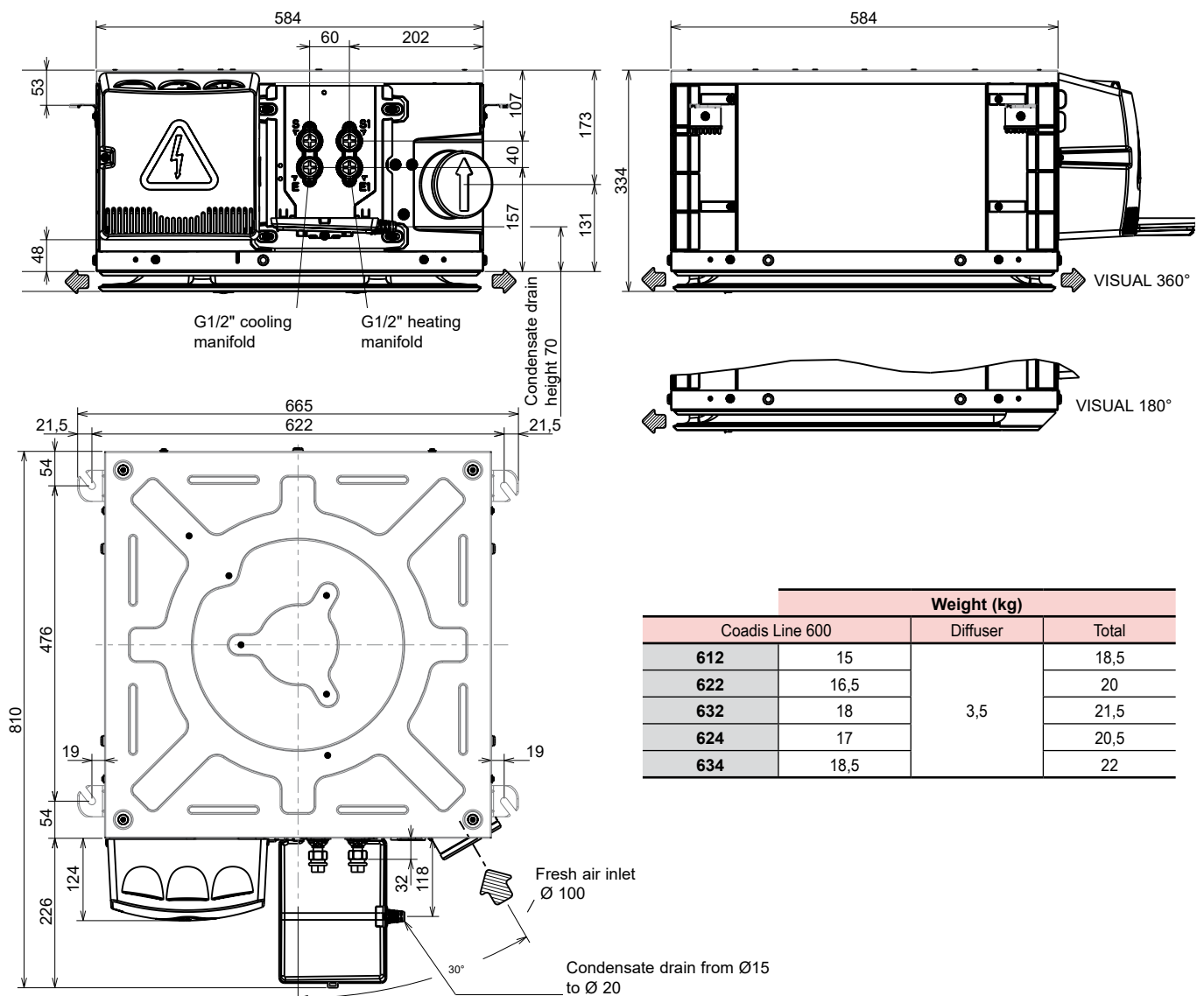

## PIPE AND VALVE POSITIONING

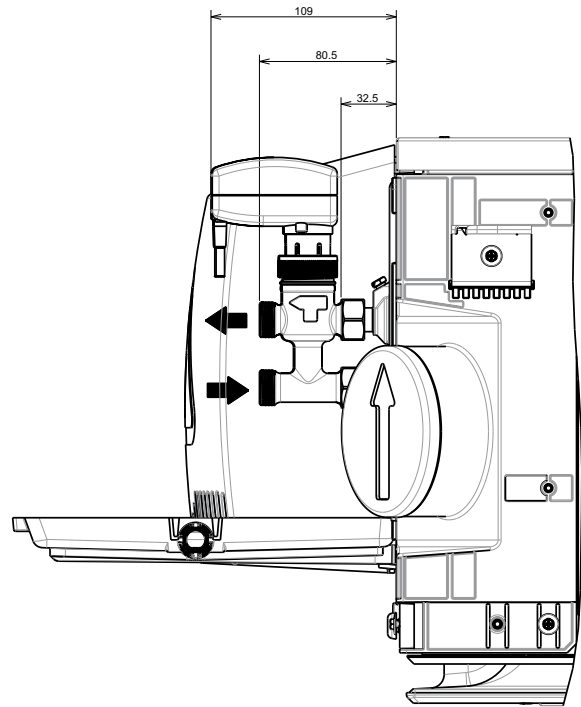
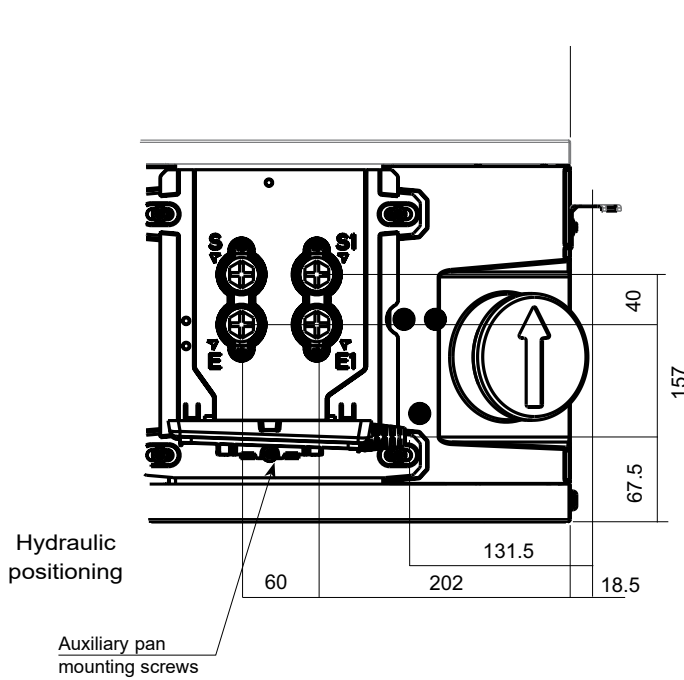

## HYDRAULIC CONNECTIONS WITH VALVE MOUNTING

### Valve and motor assembly (24V or 230V)

■ Heating/cooling assembly for valves with 3-point motors

■ Heating/cooling assembly for valves with thermo-actuators

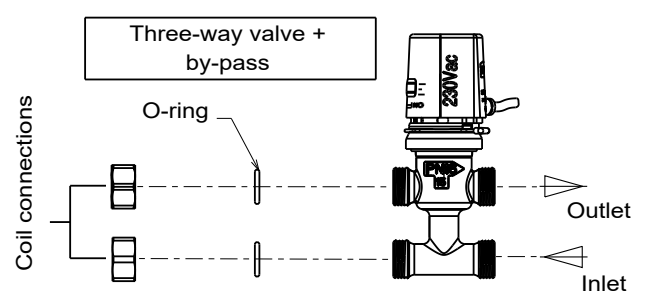
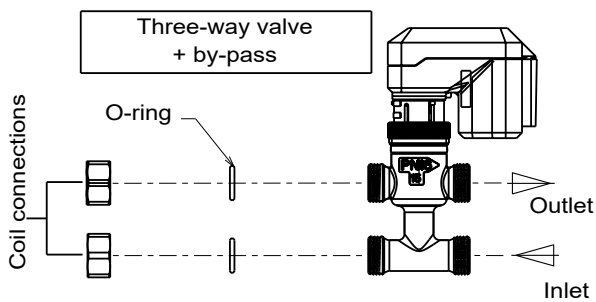
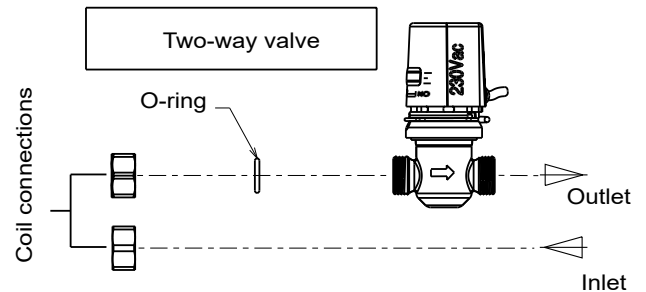
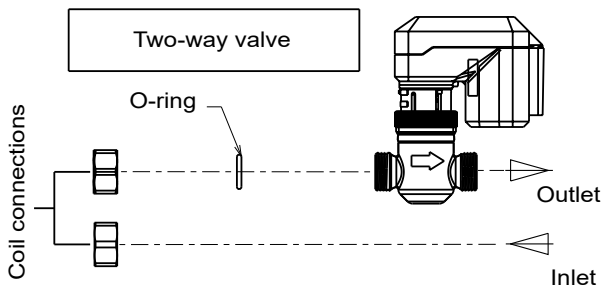

## TECHNICAL CHARACTERISTICS

### Coil capacity (L)

COADIS LINE 600		612	622	622E	632	632E	624	634
2-pipe coil		0,407	0,796	0,608	1,212	1,017		
4-pipe coil	Cold water coil						0,608	1,017
	Hot water coil						0,231	0,237

### Coil coupling diameters

Coil connection type: flush fit female threaded union nuts

Valve outlet coupling type: "male" threaded couplings to be used

COADIS LINE 600		612	622	624	632	634
2-pipe system		G1/2"	G1/2"	G1/2"	G1/2"	G1/2"
4-pipe system	Cold water coil	G1/2"	G1/2"	G1/2"	G1/2"	G1/2"
	Hot water coil	G1/2"	G1/2"	G1/2"	G1/2"	G1/2"

### Motor electrical data notes

COADIS LINE	Motor code	AC asynchronous motor			HEE brushless motor		
		612	622 - 624	632 - 634	612	622 - 624	632 - 634
Input power (W)	V5	70	70	101	38	38	56
	V4	45	45	77	17	17	38
	V3	41	41	56	12	12	21
	V2	38	38	47	8	8	15
	V1	34	34	40	5	5	11
Input current (A)	V5	0,30	0,30	0,32	0,18	0,18	0,40
	V4	0,21	0,21	0,29	0,09	0,09	0,28
	V3	0,19	0,19	0,24	0,07	0,07	0,17
	V2	0,18	0,18	0,22	0,04	0,04	0,13
	V1	0,17	0,17	0,21	0,02	0,02	0,10

**Note:** Specifications determined for 230V +/-10% - 50Hz supply.

For operation at 60Hz, the power input and rotation speed values are generally higher.

- Motor operating range: minimum return T°C: 0°C  
maximum return T°: 40°C

### Unit information plate

The information plate shows all the information needed to identify the unit and its configuration. This plate is placed on the technical side that has all the connections, above the fresh air inlet.

- ① Code
- ② Serial number
- ③ Description of the unit
- ④ Nominal motor output
- ⑤ Motor rotation speed
- ⑥ Coil type
- ⑦ Wiring diagram reference
- ⑧ Motor speed wiring
- ⑨ Maximum operating pressure
- ⑩ Electrical heater specifications (if fitted)

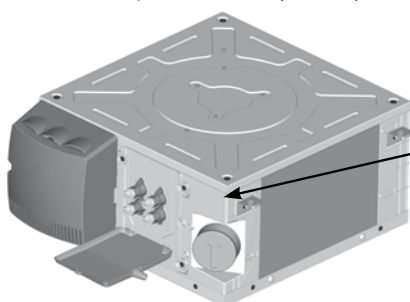

Ref. P. An./Year	Mod./Item Ref.	Designation/Description	
2016	7412910.430615	CDL 612 S PM ..	
Composants/Components		E39H TH8 230TH14	
Moteur/Motor (Ph/Hz/V)		Batterie/Hydro. coil	Fluide/Fluid
1 + N 50/60HZ 230/220V + T		2T2	EAU
P. moteur/Motor P. (W)		Elec Element (Ph/Hz/V)	Maxi pressure (bar)
74/89		1 + N 50/60HZ 230/220V	1600000 PA (166Ah)
I. moteur/Motor I. (A)		Elec Elem. P. (W)/I. (A)	Cablage/Wiring
0.32/0.38		SANS	531
tr. mm - 1/r.p.m		Elec Diagram	N° Declaration CE
		7301650	7341384.03

## TECHNICAL CHARACTERISTICS

### Condensate drain pump

The pump outlet must be connected to the wastewater pipe by a flexible tube with an internal diameter of 6 mm (not supplied).

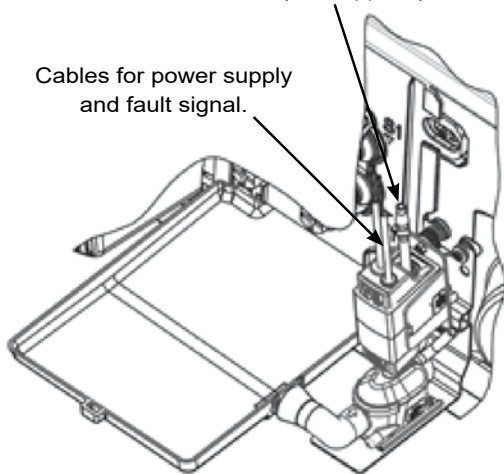

Maximum flow rate	10.4 l/h
Maximum discharge height	7 m (flow rate = 4 l/h)
Maximum pressure	10 m (flow rate = 0 l/h)
Sound level at 1 m in accordance with EN ISO 3744 and 4871 (Measurement taken at LNE, pump in water, outside of application)	20.2 dBA
Power supply	230 V +10%/-15% - 50/60 Hz – 19 W
Electrical insulation class	Class 1
Detection levels	ON: 14.7 mm, OFF: 10.7 mm, AL: 17 mm
Safety switch	NF: 5 A resistance – 250 V Contacts made from AgNI 90/10, gold-plated.
Thermal protection (overheating)	70°C (automatic restart)
Operating cycle (duty factor)	100%
Protection (according to NF EN 60529)	IP64
Safety standard	CE
RoHS directive	Compliant
WEEE directive	Compliant

DE05UCC pump performance: water flow rate in litres per hour (-15 %/+20 %)

Discharge height	Horizontal length of discharge pipe			
	5 metres	10 metres	20 metres	30 metres
1 m	10.4	9.1	8.3	7.3
2 m	8.5	7.8	7	6.4
3 m	7.9	7.1	6.3	5.8
4 m	7	6	5.3	4.9

Operating limit:

Drainage: → 6 mm int. flexible pipe, → 8.8 mm end piece. This accessory must be paired with a valve control to allow the upper safety limit to control the valve's closure (stop condensate).

$$\text{Condensate flow rate (l/h)} = \frac{\text{Total capacity} - \text{Sensible capacity (W)}}{680}$$

### Electrical heaters

2 single-pipe 230/1/50 electrical elements inserted into the aluminium housing and bent around the hydraulic coil.

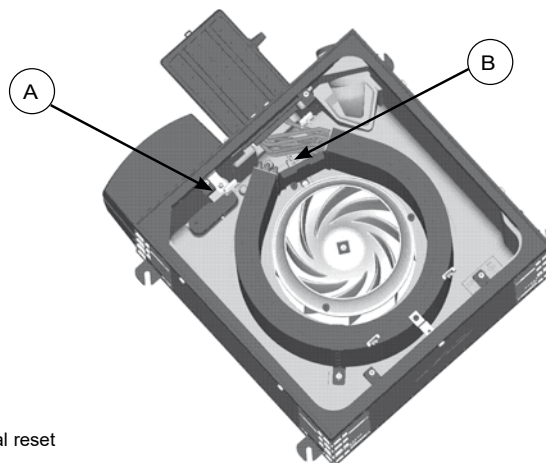

- (A) Temperature limiter with manual reset
- (B) Temperature limiter with automatic reset

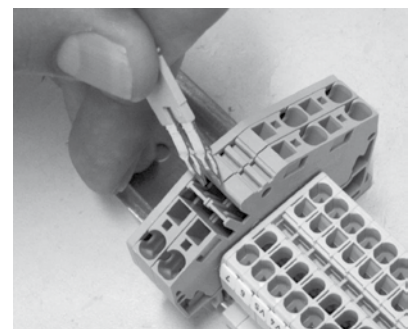

Remove shunt to deactivate a heater (reduction of 300 W)

## Operating speed selection

### ■ Asynchronous motor

All speeds are connected and wired to the terminal.

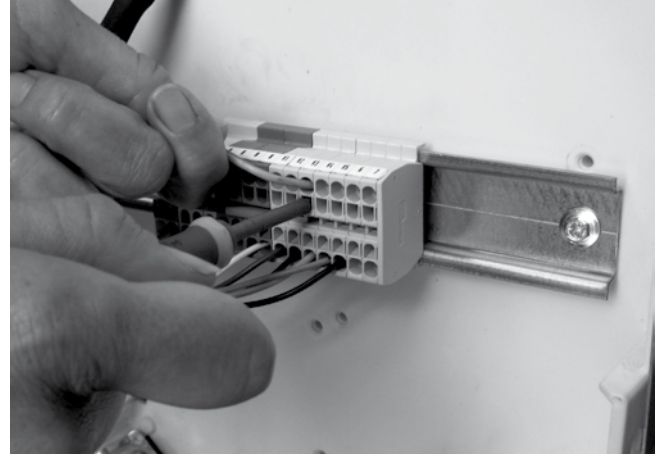
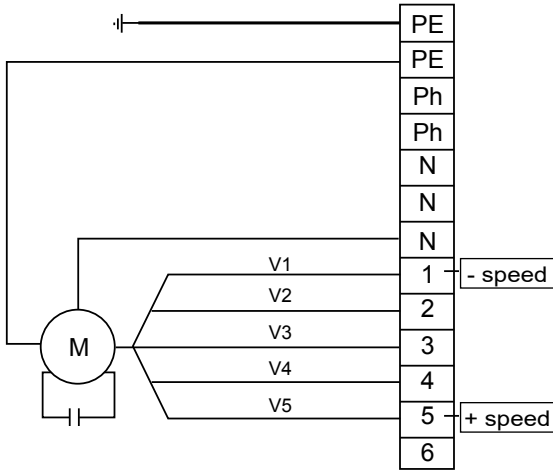

The customer must cable the speeds for the thermostat at the top of the terminal block between V1 and V5.

### ■ HEE motor

Operating speed selection:

- With 0 - 10 V control, adjustment via the controller
- With 3-speed on/off control, adjustment via the control unit (option)

Note: For more information, refer to instruction manual N11-47

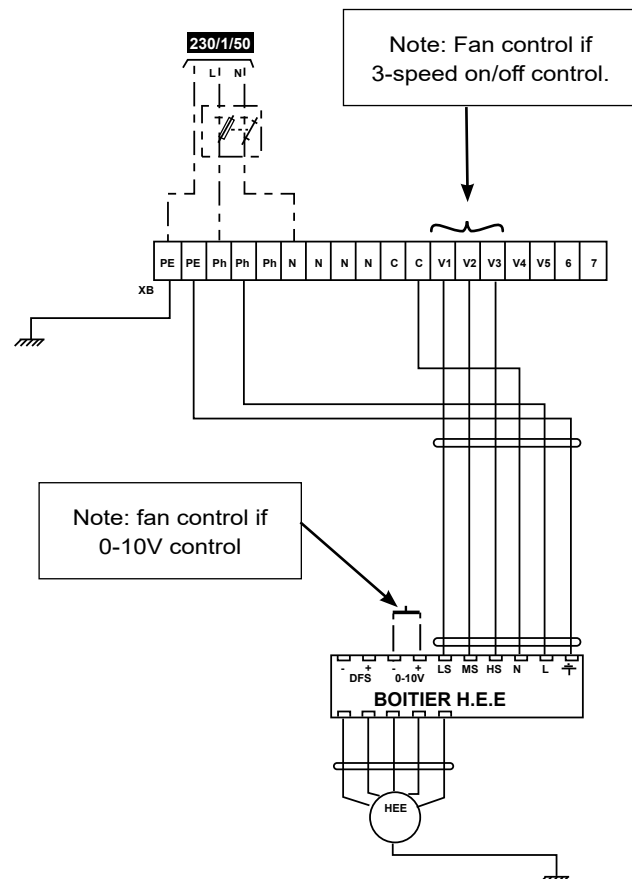
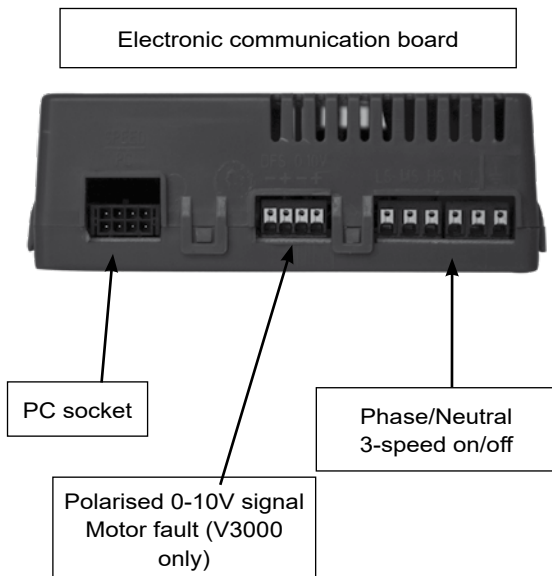

## 2T/4T AC MOTOR PERFORMANCE

COADIS LINE	Motor code	Air flow m <sup>3</sup> /h	2-pipe and 4-pipe systems			Power input W	LW dB(A)	Comfort level (ISO or NR)	Average increase of air temperature (in K) 230/1/50 auxiliary electrical heater	
			Cooling capacity (W)		Heating capacity (W)				2R	
			Total	Sensible						
612	V5	610	2 180	1 991	2 563	70	59	42		
	V4	440	1 765	1 582	2 051	45	49	32		
	V3	380	1 599	1 425	1 852	41	46	29		
	V2	310	1 429	1 256	1 627	38	42	25		
	V1	235	1 250	1 058	1 379	34	37	19		
622	V5	590	3 501	2 790	3 618	70	59	42		
	V4	420	2 662	2 054	2 713	45	51	34		
	V3	360	2 347	1 779	2 363	41	47	30		
	V2	290	2 016	1 488	1 988	38	42	25		
	V1	215	1 630	1 173	1 592	34	35	18		
622E	V5	590	2 635	2 336	2 992	70	59	42	900 W (2R)	4,5
	V4	420	2 114	1 818	2 385	45	51	34		6,4
	V3	360	1 930	1 604	2 140	41	47	30		7,4
	V2	290	1 699	1 362	1 868	38	42	25		9,2
	V1	215	1 468	1 108	1 565	34	35	18		12,4
624	V5	590	2 635	2 336	2 984	70	59	42		
	V4	420	2 114	1 818	2 464	45	51	34		
	V3	360	1 930	1 604	2 257	41	47	30		
	V2	290	1 699	1 362	2 029	38	42	25		
	V1	215	1 468	1 108	1 781	34	35	18		
632	V5	775	5 173	3 881	4 853	101	62	44		
	V4	660	2 262	3 318	4 176	77	58	40		
	V3	525	3 630	2 664	3 359	56	51	34		
	V2	460	3 226	2 348	2 962	47	48	30		
	V1	405	2 907	2 097	2 648	40	45	27		
632E	V5	775	4 401	3 493	4 633	101	62	44	1200 W (2R)	4,6
	V4	660	3 833	3 009	4 006	77	58	40		5,4
	V3	525	3 169	2 442	3 263	56	51	34		6,8
	V2	460	2 854	2 173	2 901	47	48	30		7,7
	V1	405	2 600	1 955	2 615	40	45	27		8,8
634	V5	775	4 401	3 493	3 363	101	62	44		
	V4	660	3 833	3 009	3 025	77	58	40		
	V3	525	3 169	2 442	2 623	56	51	34		
	V2	460	2 854	2 173	2 430	47	48	30		
	V1	405	2 600	1 955	2 275	40	45	27		

### EUROVENT conditions

Eurovent certified values

Cooling mode: water temperature: 7/12°C, inlet air temperature: 27°C - 19°C (WB)  
 Heating temperature (2P): water temperature: 45/40 °C, inlet air temperature: 20 °C  
 Heating temperature (4P): water temperature: 65/55 °C, inlet air temperature: 20 °C

## 2T/4T HEE MOTOR PERFORMANCE

COADIS LINE	Control voltage (V)	Air flow m <sup>3</sup> /h	2-pipe and 4-pipe systems			Power input W	LW dB(A)	Comfort level (ISO or NR)	Average increase of air temperature (in K) 230/1/50 auxiliary electrical heater	
			Cooling capacity (W)		Heating capacity (W)				2R	
			Total	Sensible						
612 HEE	6,7	610	2 160	1 969	2 582	38	59	42		
	4,9	440	1 745	1 561	2 070	17	49	32		
	4,2	380	1 577	1 401	1 872	12	46	29		
	3,4	310	1 403	1 229	1 650	8	42	25		
	2,5	235	1 221	1 029	1 404	5	37	19		
622 HEE	6,7	590	3 468	2 758	3 644	38	59	42		
	4,9	420	2 637	2 027	2 737	17	51	34		
	4,2	360	2 322	1 752	2 389	12	47	30		
	3,4	290	1 984	1 457	2 016	8	42	25		
	2,5	215	1 596	1 142	1 620	5	35	18		
622E HEE	6,7	590	2 609	2 309	3 014	38	59	42	900 W (2R)	
	4,9	420	2 090	1 792	2 408	17	51	34		
	4,2	360	1 904	1 577	2 164	12	47	30		
	3,4	290	1 666	1 331	1 895	8	42	25		
	2,5	215	1 430	1 076	1 594	5	35	18		
624 HEE	6,7	590	2 609	2 309	2 997	38	59	42		
	4,9	420	2 090	1 792	2 477	17	51	34		
	4,2	360	1 904	1 577	2 272	12	47	30		
	3,4	290	1 666	1 331	2 045	8	42	25		
	2,5	215	1 430	1 076	1 799	5	35	18		
632 HEE	7,9	775	5 132	3 839	4 891	56	62	44		
	6,7	660	4 425	3 281	4 200	38	58	40		
	5,3	525	3 596	2 630	3 389	21	51	34		
	4,6	460	3 194	2 317	2 990	15	48	30		
	3	290	2 190	1 530	1 970	6	38	19		
632E HEE	7,9	775	4 364	3 454	4 670	56	62	44	1200 W (2R)	
	6,7	660	3 798	2 973	4 038	38	58	40		
	5,3	525	3 136	2 410	3 292	21	51	34		
	4,6	460	2 822	2 142	2 929	15	48	30		
	4,1	405	2 570	1 927	2 640	11	45	27		
634 HEE	6,7	660	3 798	2 973	3 039	38	58	40		
	5,3	525	3 136	2 410	2 637	21	51	34		
	4,6	460	2 822	2 142	2 444	15	48	30		
	4,1	405	2 570	1 927	2 288	11	45	27		
	3	290	2 040	1 470	1 960	6	38	19		

### EUROVENT conditions

Eurovent certified values

Cooling mode: water temperature: 7/12°C, inlet air temperature: 27°C - 19°C (WB)  
 Heating temperature (2P): water temperature: 45/40 °C, inlet air temperature: 20 °C  
 Heating temperature (4P): water temperature: 65/55 °C, inlet air temperature: 20 °C

## TYPE KEY

<b>VISUAL 180°</b>	Coil →		2 heating or cooling pipes					
	Motor type →		HEE MOTOR			Asynchronous MOTOR		
	Size →		612T-B	622T-B	632T-B	612T-S	622T-S	632T-S
	Air handling casing	Code	7401351	7401352	7401353	7401354	7401355	7401356
	Diffusion interface VISUAL 180° EPURE filter	Code	7510141					
	Diffusion interface VISUAL 180° G3 filter	Code	7510144					
	Coil →		4 heating and cooling pipes					
	Motor type →		HEE motor		5-speed motor			
	Size →			624T-B	634T-B		624T-S	634T-S
	Air handling casing	Code		7401357	7401358		7401359	7401360
	Diffusion interface VISUAL 180° EPURE filter	Code		7510141			7510141	
	Diffusion interface VISUAL 180° G3 filter	Code		7510144			7510144	
	Coil →		2 heating or cooling pipes + electrical heater					
	Motor type →		HEE motor		5-speed motor			
Heater →			900W	1200W		900W	1200W	
Size →			622TE-B	632TE-B		622TE-S	632TE-S	
Air handling casing	Code		7401361	7401362		7401363	7401364	
Diffusion interface VISUAL 180° EPURE	Code		7510141			7510141		
Diffusion interface VISUAL 180° G3 filter	Code		7510144			7510144		

<b>VISUAL 360°</b>	Coil →		2 heating or cooling pipes					
	Motor type →		HEE MOTOR			Asynchronous MOTOR		
	Size →		612T-B	622T-B	632T-B	612T-S	622T-S	632T-S
	Air handling casing	Code	7401351	7401352	7401353	7401354	7401355	7401356
	Visual 360° diffusion interface (4-way) EPURE filter	Code	7510137					
	Visual 360° diffusion interface (4-way) G3 filter	Code	7510139					
	Coil →		4 heating and cooling pipes					
	Motor type →		HEE motor		5-speed motor			
	Size →			624T-B	634T-B		624T-S	634T-S
	Air handling casing	Code		7401357	7401358		7401359	7401360
	Diffusion interface Visual 360° (4-way) EPURE filter	Code		7510137			7510137	
	Diffusion interface Visual 360° (4-way) G3 filter	Code		7510139			7510139	
	Coil →		2 heating or cooling pipes + electrical heater					
	Motor type →		HEE motor		5-speed motor			
Heater →			900W	1200W		900W	1200W	
Size →			622TE-B	632TE-B		622TE-S	632TE-S	
Air handling casing	Code		7401361	7401362		7401363	7401364	
Diffusion interface Visual 360° (4-way) EPURE filter	Code		7510137			7510137		
Diffusion interface Visual 360° (4-way) G3 filter	Code		7510139			7510139		



## OPTIONS (FACTORY-FITTED)

Description		
Factory-fitted condensate drain pump	Code	E046512
Factory-fitted riser	Code	E046511
Factory-fitted frame for 675 x 675 suspended ceiling tiles	Code	E046513
Finishing trim frame + sub-frame for Staff ceilings	Code	E049700

## ACCESSORIES (AVAILABLE SEPARATELY)

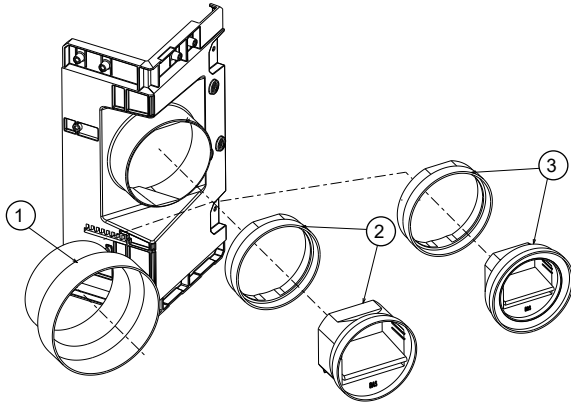

- 1) Ø100/Ø125 mm adapter
- 2) Air flow controller 60/75/90 m³/h
- 3) Air flow controller 15/30/45 m³/h

Description		
Condensate drain pump kit for model 600 only	Code	7498012
Resilient mount supplied separately (4 per device)	Code	0219453
Extension kit	Code	7510131
Self-adjustable module kit (diam. 100 mm)	15/30/45 m³/h	Code 7320014
	60/75/90 m³/h	Code 7320015
AN adapter kit, diam. 100/125 mm	Code	7320016
Frame kit for suspended ceiling (675x675)	Code	7496171
HEE motor speed adjustable unit kit for 3-speed on/off control	Code	7213179
Finishing trim frame + sub-frame for plaster ceilings	Code	7510114+7410101

## Flexible connections

Assembly	Figure	Description	Code	600
<b>For 2-pipe coils</b>				<b>G1/2" customer side coupling</b>
All without valve		2 M1 9 mm thick insulated flexible couplings EPDM pipe + PN10 stainless steel braid length 300 mm Male coupling with flat face/Female rotary coupling on customer side	Code	2 x 5202288
All 4-way valve		2 M1 9 mm thick insulated flexible connections EPDM pipe + PN10 stainless steel braid length 300 mm Female rotary couplings on both sides	Code	2 x 5202289
All 2-way valve		2 M1 9 mm thick insulated flexible connections EPDM pipe + PN10 stainless steel braid length 300 mm : 1 with Male coupling with flat face/Female rotary coupling on the customer side 1 with Female rotary couplings on both sides	Code	5202288 + 5202289
<b>For 4-pipe coils</b>				<b>Customer side coupling Heating G1/2" Cooling G1/2"</b>
All without valve		EPDM pipe + PN10 stainless steel braid length 300 mm Male coupling with flat face/Female rotary coupling on customer side HEATING: 2 non-insulated COOLING: 2 insulated - M1 9 mm thick	Code	HEATING: 2 x 7247868 COOLING: 2 x 5202288
All 4-way valve		EPDM pipe + PN10 stainless steel braid length 300 mm Female rotary couplings on both sides HEATING: 2 non-insulated COOLING: 2 insulated - M1 9 mm thick	Code	HEATING: 2 x 7247837 COOLING: 2 x 5202289
All 2-way valve		4 EPDM pipe flexible connections + PN10 stainless steel braid length 300 mm: 2 with Male coupling with flat face / Female rotary coupling on the customer side 2 with Female rotary couplings on both sides HEATING: 2 non-insulated COOLING: 2 insulated - M1 9 mm thick	Code	HEATING: 7247868 + 7247837 COOLING: 5202288 + 5202289

## SPECIFICATION TEXT

- **The comfort units** must comply with standards and regulations in force, in particular: EN ISO 7730 (thermal comfort), EN 779 (filters), EN 1216 (water coils), EN 50022 (DIN rails), NF C15-100 (electrical components), NF S90-351 (health, airborne contamination control) and the circular DGS no. 97/311 (disinfection of air conditioning systems). Eco-designed in accordance with standard EN14062 and in compliance with environmental certification ISO 14001. They will be manufactured according to the quality assurance standard ISO 9001, EUROVENT and will have the CE mark. The unit will be easy to maintain and the supply air/return air system of the all-in-one type.
- **The base** will be designed in high-density PSE with very low TVOC emissions, to provide thermal and sound insulation. The PSE will be classed A+ in accordance with the order of 19th April 2011 concerning the classification of construction materials based on their volatile pollutant emissions. A base panel in galvanised steel to support the internal components and lateral reinforcements in ABS will ensure a rigid construction. It will be easy to wash from the inside and non-erodible. The fire rating will be M1. The components that make up the base must be able to be separated to enable optimal recycling of the materials at the end of life and reduce the environmental impact. Bonded insulation will not be permitted. The dimensions of the base must allow it to be integrated in 600x600mm and 675x675mm suspended ceiling tiles. Its lightweight design will enabling optimal handling and quicker commissioning on site. The mounting brackets, which are equipped with an anti-slip system for the threaded rods, will make the unit easier to fit.
- Anti-vibration mounts located around the base will enable the unit to be automatically centred between the suspended ceiling profiles, in order to reduce the commissioning time. **The Coanda effect diffusion system** will be integrated in the unit. The naturally optimised single vent design with narrow opening means it does not require adjustment to operate efficiently in any type of room. Any adjustment system that changes the sound of the unit by reducing the supply air section (e.g. dampers) will not be permitted. It will enable horizontal diffusion at an angle of 180° or 360° (Visual interface), completely eliminating radiation transfer caused by the walls when the jet is falling vertically outside the occupied space (NF EN13779) and ensure uniform comfort in line with the stipulations of standard ISO 7730. Its peripheral single-vent design will allow a high rate of induction (injection of ambient air in the air stream) over the entire length so that the desired comfort temperature can be reached more quickly.
- **The VISUAL180 ° or 360 ° supply/return interface** in RAL 9010 will be completely insulated by a PSE unit which will fully surround the panel. It is removable to enable easy maintenance, and will allow complete access from underneath to all of the internal components (fan motor assembly, coil, condensate pan, etc.) without the need to remove the unit or open the suspended ceiling. Smooth and free from corners where dust could accumulate, the single-vent diffusion system enables quick, easy cleaning. **The FLEXIWAY** function allows the VISUAL 180° and 360° interfaces to be swapped over to quickly adjust between office and open plan spaces without removing the unit.
- **The air intake** is via a micro-perforated return air grille in RAL 9010, integral to the unit and concealing the filter. It can be opened easily without tools, allowing the filter to be accessed in under 3 seconds and at very low cost. The hinge-mounted grille will allow work to be carried out on the unit in complete safety.
- The EPURE function (air purification system) must exceed the WHO's recommendations on particle removal, reducing PM2.5 particulates to below 10 µg/m3 in less than an hour. It is to be fitted with an air filter made of polypropylene with an M1 fire rating, that will not release glass fibres. The filter should be a high energy efficiency multi-pleated filter with a filter area of at least 10 times the intake grille surface area. A minimum space of 20 mm must be left between the air intake and the filter in order to ensure that the entire filter area is used, thereby improving the ambient air quality. Its high retention capacity ensures an increased service life (flat filters will not be permitted). In order to reduce waste at the end of the service life, it must be able to be completely incinerated with no sorting of materials necessary. It must be accessible via the return air grille to enable its replacement in less than one minute.
- **The water coil** will be made of copper tubes and continuous fins in seamed aluminium. The connections will have one-piece couplings with a 40 mm centre distance and an integrated swivel nut to reduce the number of intermediate couplings, thereby reducing the risk of leaks (direct assembly of valves). The coils will be equipped with air bleed and draining valves. They will be tested under extreme conditions with a minimum test pressure of 24 bar. In order to reduce energy consumption and simplify commissioning, it will be possible to fit them with automatically adjusted differential pressure valves to ensure the water flow rate is maintained, once it has been set with the manual handle.
- **The main condensate pan** will be in high-density sealed non-corrodible PSE. Its naturally sloped design will allow it to drain condensate directly to the auxiliary pan, to prevent the water from stagnating and the risk of bacteria spreading. It will be possible to remove the main pan from underneath without the need to open the suspended ceiling.
- **The auxiliary condensate pan** in ABS will enable the condensate produced by the cold water control valve to be recovered. Its diamond point-shaped design will allow condensate to be drained directly via a pipe connected to the pan through a multi-diameter end-piece (15 to 20 mm). As far as possible, units without condensate drain pumps should be installed (condensate draining via gravity through 4 to 11 m of pipe via the auxiliary pan). If this is not sufficient, a condensate drain pump will be fitted with a high-safety device and a water control valve.
- **The additional electrical heater** running in 230 V single-phase must be shielded with stainless steel. It should be placed downstream of the water coil in order to save energy (for simultaneous hot water and auxiliary electrical heater usage). The unit is to be fitted with safety limiters that comply with the applicable standards. All electrical heaters with incandescent wires or sacrificial fuses will be prohibited. It will be possible to reduce the power of the electrical heater on site.

# COADIS LINE 600

Comfort units  
COANDA effect cassette

- **The fan motor assembly** mounted on anti-vibration mounts, will be fitted with a low-consumption HEE motor with brushless technology (single-phase 230 V 50/60 Hz); it may be controlled by a progressive control signal (0-10 V or 3-speed ON/OFF) with no need for an expansion board. It will be fitted with an automatic overload protection with alarm report via KNX bus. The centrifugal impeller with profiled vanes will be balanced to prevent noise from vibrations. The system mounting it on the drive shaft will be fitted with a foolproofing device which prevents installation if incorrectly positioned, in order to simplify maintenance. The fan motor assembly will be removable from underneath.
- **An electrics box** that is enclosed and with large dimensions, fitted with a DIN rail, will be able to accommodate and protect all the control components from dust. The safety of the electrical cables must be ensured using cable glands. The electrical and hydraulic feeds must both be on the same side to facilitate maintenance operations. In order to ensure reliability, the control will be factory-fitted (except for the room terminal) to eliminate any risks of leaks, for electrical safety and for the proper protection of components.
- **The fresh air** enters through a smooth metal sleeve (with no flow control) or via a self-adjusting spigot and module assembly designed to supply the determined flow rate with a  $\Delta P$  between 50 and 100 Pa.
- **Resilient mounts** will be placed between the unit's mountings and the threaded rods to prevent any transmission of noise.
- **Guarantees**

The manufacturer guarantees the equipment's performance, and will provide the documents attesting to the equipment's compliance with the attached specifications and with the STANDARDS, in particular the heating and cooling capacity (total and sensible), the air flow, the motor power input, the efficiency of the filters and the sound power spectrum. Using a simulation tool, the manufacturer of the terminal units must be able to give the relevant comfort indices or the values in compliance with the standard EN ISO 7730. The system start-up and maintenance guide for the unit must be in the language used in the country of installation. The manufacturer's technical specifications and the equipment's sound pressure must be given in the **documents to be appended to the submission.**

This document is not legally binding. As part of its continuous drive to improve its equipment, CIAT reserves the right to make any technical modifications without prior notice.  
Ref.: NA 19.696 A

## Head office

700 Avenue Jean Falconnier - B.P. 14  
01350 - Culoz - France  
Tel.: +33 (0)4 79 42 42 42  
Fax: +33 (0)4 79 42 42 10  
www.ciat.com



## CIAT Service

Technical support: 0 892 05 93 93 (€0.34/min)  
Spare parts: 0 826 96 95 94 (€0.15/min)  
pdrfrance@ciat.utc.com - PDRGarantie@ciat.fr

